

MITSUBISHI

MT160

MT160D

MT180

MT180D

INSTRUCTION BOOK



mitsubishi

MT160 MT180
MT160D MT180D

INSTRUCTION BOOK

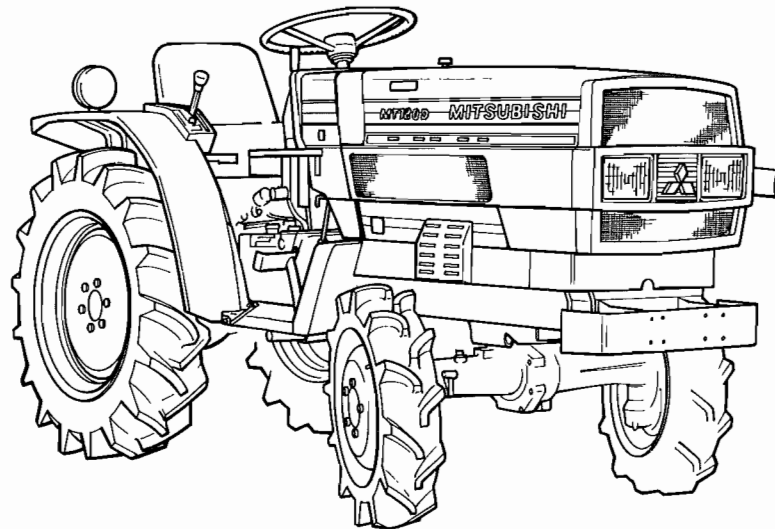

 **MITSUBISHI AGRICULTURAL MACHINERY CO., LTD.**

6-3, KANDA KAJICHO 3-CHOME, CHIYODA-KU,
TOKYO JAPAN

INTRODUCTION

This instruction manual contains information on the operation, lubrication and maintenance of your tractor. The information contained is comprehensive and essential, and is designed to assist you, even if unexperienced, in utilizing your tractor.

How well your tractor continues to give satisfactory performance depends greatly upon the manner in which it is operated. It is, therefore, requested that this manual be read carefully and kept ready for use so that the operation and maintenance services will properly be carried out in order to keep the tractor in top mechanical condition at all times.

Should any information as to your tractor be required, consult your local dealer or distributor stating the machine and engine serial numbers of the tractor concerned.

We are sure you will be happy with your tractor.

NOTE:

Expressions such as LEFT, RIGHT, FRONT or REAR used in this manual should be understood in accordance with following rules:

FRONT means the front grill end while REAR means the lifting arm end of the tractor.

LEFT or RIGHT means the left or right hand side of the tractor looking forward from operator's seat.

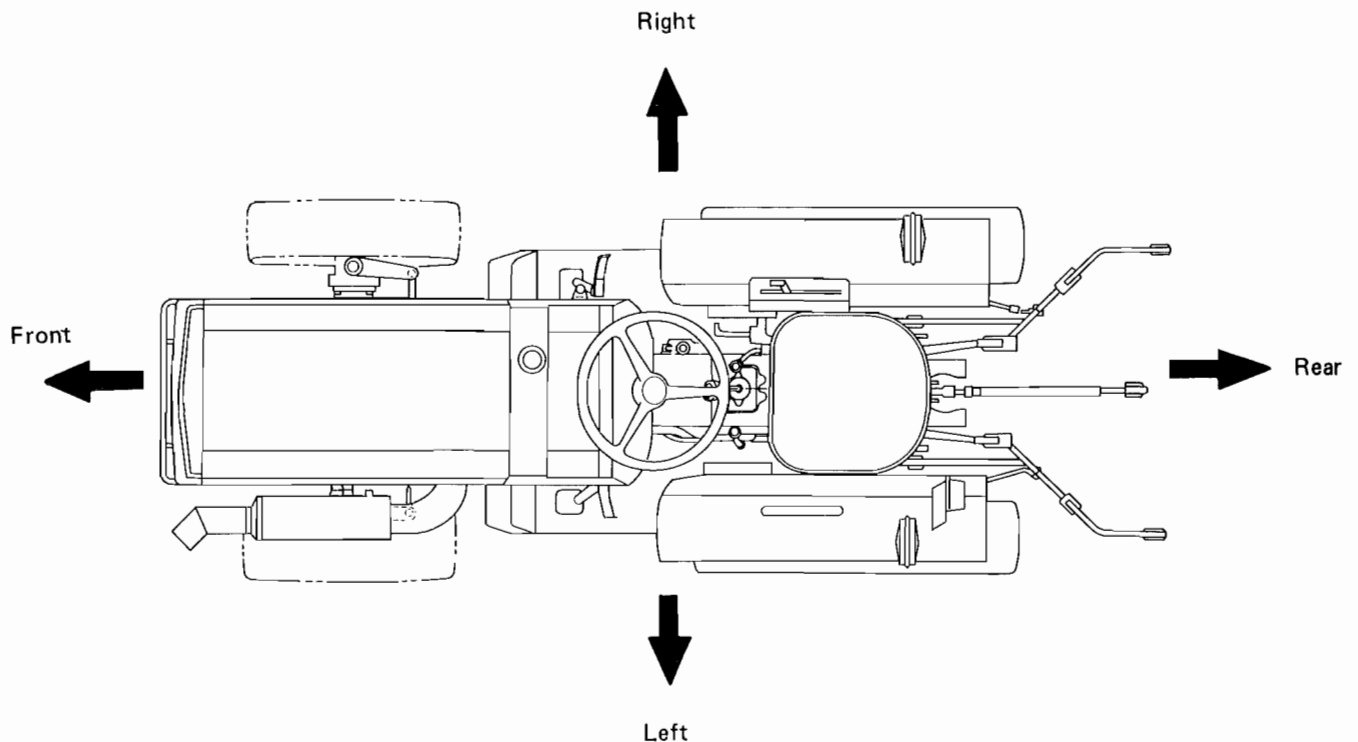

SERIAL NUMBERS

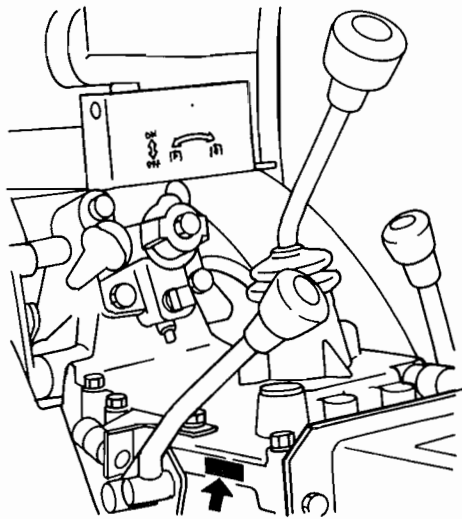

Tractor serial number

It is located at the right side of the transmission case specifically upper side (under HST filter).

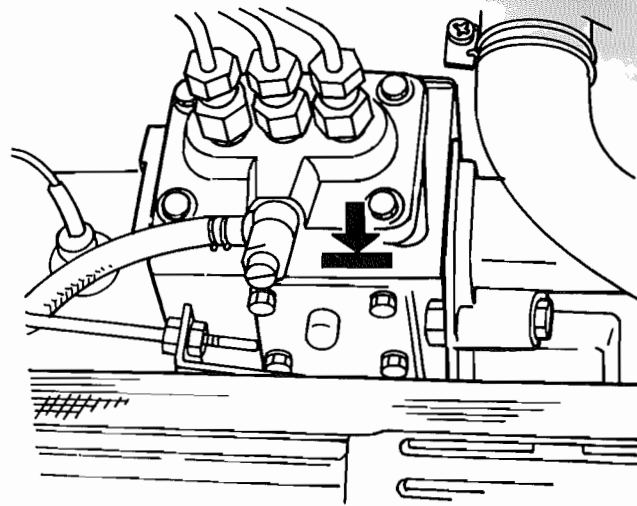

Engine serial number

It is located at the right hand side of the cylinder block, specifically injection pump side.

NOTES, CAUTIONS and WARNINGS

NOTES, CAUTIONS and WARNINGS are used in this manual to emphasize important and critical instructions. They are used for the following conditions:

NOTEAn operating procedure, condition, etc., which is essential to highlight.

CAUTIONOperating procedures, practices, etc., which if not strictly observed, will result in damage to or destruction of machine.

WARNINGOperating procedures, practices, etc., which if not correctly followed, will result in personal injury or loss of life.

TREATMENT OF A NEW TRACTOR

All components of your tractor are subject to stringent checking during assembly in the factory. However, a new tractor should be carefully checked over by the operator himself. For the first 25 ~ 50 hours operation, heavy duty work should be avoided. If heavy duty work is unavoidable, drive in a gear one stage lower than you would normally use, and run the engine at lower rpm.

“IMPORTANT” 50-HOUR SERVICE

When the tractor is brand new, after the first 50 hours running, the following service, maintenance and checking should be carried out by this instruction book.

1. Replace the engine oil filter and engine oil.

2. Replace the transmission oil.
3. Retighten all bolts and nuts, paying special attention to those for steering linkage and wheel.
4. Check and adjust the fan belt tension.
5. Check the wheels to see if their condition is good and tire pressure is correct.
6. Retighten the cylinder head bolts and adjust valve clearances.
7. Front axle diff. case and gear case oil replacement of 4-wheel drive tractor.
8. Cooling water replacement.
9. Air cleaner element cleaning.
10. Clean the fuel filter.
11. Check the front hub for end-play.
12. Check the battery electrolyte.
13. Clean the hydraulic oil filter.

This 50-hour Service is an essential procedure for keeping the tractor in top condition, so it must be done properly.

CONTENTS

SECTION 1. SAFETY PRECAUTIONS	
A. General Operating Safety Precaution	1
B. Basic Safety Requirements for Maintenance	1
C. Operation of the Tractor	2
SECTION 2. EXTERNAL VIEW AND NOMENCLATURE OF EACH PART	.6
SECTION 3. INSTRUMENTS AND CONTROLS	.8
Key Start Switch	9
Glow Signal	9
Glow Plug	9
Tractor Meter	9
Battery Charge Warning Lamp	9
Oil Pressure Warning Lamp	9
Water Temperature Warning Lamp	10
Fuel Meter	10
Light Switch	10
Check Button	10
Horn Button	10
Combination flash and turn signal switch	10
Throttle Lever	10
Clutch	10
Brake	11
Parking Brake	11
Foot Speed Control Pedal	11
Power Take Off	11
Differential Lock	12
8-Speed Transmission	13
4-Wheel Drive Shift Lever	13
Safety Starter Switch	13
SECTION 4. OPERATION	.14
Before Operating the Tractor	14
Starting the Engine	14
Starting in Cold Weather	14
Engine Block Heater	14
After the Engine is Started	14
Driving the Tractor	14
Stopping the Tractor	15
Tread Adjustment	15
Front	15
Rear	16
Rear Wheel Installation	16
Ballast Weight	16
Tire Pressure	16

Operator's Seat	17
Tool Box	17
Drawbar	17
3-Point Linkage	17
Hydraulic System	17
Flow Control Knob	18
External Hydraulic Service	19
Power Take Off for Front Loader (Option)	19
P.T.O. Guard	19
SECTION 5. REGULAR MAINTENANCE GUIDE	20
Service Schedule	20
Service Schedule Chart	20
Daily Inspection	20
A-Service (Every 50 hours of operation)	20
50-Hour Service for a New Tractor	21
50-Hour Service for Other than New Tractor	21
B-Service (Every 100 hours of operation)	21
C-Service (Every 200 hours of operation)	21
D-Service (Every 400 hours of operation)	21
Maintenance Interval Chart	22
Lubrication Table	23
Greasing Diagram	24
SECTION 6. PREVENTIVE SERVICE INSTRUCTION	26
Hood and Side Covers Opening/Closing	26
Checking the Radiator Coolant Level	26
Coolant Replacement	26
Precautions on Cooling System in Cold Weather	26
Antifreeze	26
Fuel System Air Bleeding	27
Fuel Filter Air Bleeding	27
Fuel Pump Air Bleeding	27
Fuel Pipe Air Bleeding	27
Fuel Filter Element Replacement	28
Cleaning the Fuel Tank	28
Checking the Engine Oil Level	28
Engine Oil Replacement	28
Engine Oil Filter Replacement	29
Injection Nozzle Inspection	29
Cylinder Head Bolt Tightening	29
Valve Clearance Adjustment	30
Valve Clearance Adjustment Procedure	30

Air Cleaner	30
Fan Belt Tension Adjustment	31
Battery (Outside North America)	31
Booster Connection	32
Proper Procedure for Booster Connection	32
Proper Procedure for Removing Booster Cable	32
Proper Battery Service and Tips for Safety	33
Checking the Electrolyte Level	34
Battery Recharging	34
Lubricating the Tractor Meter Cable	34
Transmission Oil Replacement	34
Creaning the Hydraulic Oil Filter	35
Checking the 4WD Front Axle Oil Level and its Replacement	35
Checking the Oil Level	35
Replacing the Oil of Front Axle	35
Cleaning the Radiator Screen	36
Cleaning the Radiator	36
Cleaning the Inside of Radiator	36
Clutch Pedal Adjustment	36
Brake Pedal Adjustment	37
Differential Lock Pedal Adjustment	37
Throttle Lever Adjustment	37
Hydraulic Control Adjustment	38
Position Control Adjustment	38
Hydraulic Pump Relief Valve	38
AC Generator	38
Starting Motor	39
Regulator	39
Glow Plug	39
Fuse	39
SECTION 7. STORING	40
Storage	40
Reoperation After Storage	40
SECTION 8. WIRING DIAGRAM	41
SECTION 9. SPECIFICATIONS AND DATA	42
Engine	42
Cooling System	42
Fuel System	42
Lubrication System	42
Air Cleaner	42
Governor	42
Electrical System	42
Chassis Dimensions	43

Clutch	43
Transmission	43
Power Take Off	43
Brake	43
Steering	43
Hydraulic System	44
3-Point Linkage	44
Drawbar	44
Tire	44
Travelling Speed	45
Capacities	45

SECTION 1. SAFETY PRECAUTIONS

REMEMBER: "SAFETY" IS ONLY A WORD UNTIL IT IS PUT INTO PRACTICE

Improper handling of the tractor could lead to an accident. Prior to the operation of the tractor, be sure to read this Manual carefully and have a thorough understanding of all of the contents. In particular, the instructions given in this section entitled "Safety Precautions" must be strictly followed.

A. GENERAL OPERATING SAFETY PRECAUTION

1. Observe all the safety precautions in this manual when operating the tractor.
2. Operate the tractor while wearing tight clothing that allows easy movement. Avoid loose jackets, mufflers, ties, scarves, or loose shirt sleeves to prevent from being caught by moving parts.

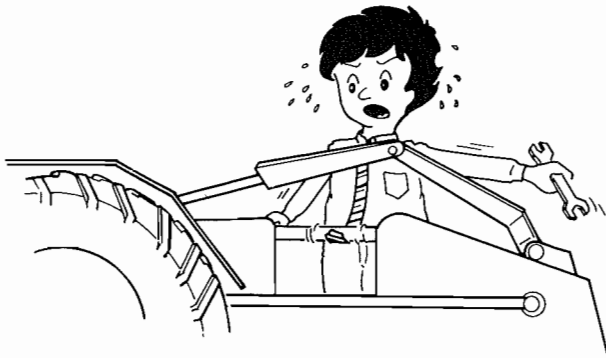

3. Always work when you are in good physical condition by taking sufficient rest to avoid overwork.
4. Do not allow children or adults having no knowledge of the tractor or tractor operation, to operate the tractor.
5. Never allow riders on the tractor, linkage drawbar or attachments while travelling and operating them.

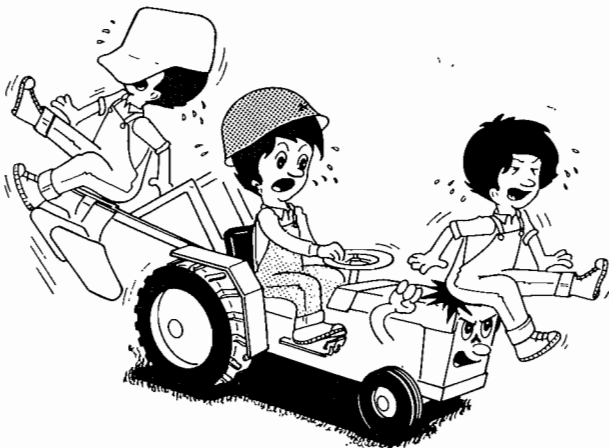

B. BASIC SAFETY REQUIREMENTS FOR MAINTENANCE

Always follow these maintenance instructions before operating the tractor:

1. Immediately repair the head lights and work lamps required to conform to traffic regulations where the tractor is operated.

2. Keep tractor steps clean to avoid accidents due to slippage.
3. Cover the PTO shaft with a guard when not using.
4. Be sure to apply the brake and lower any attachment or implement before disassembling any part.
5. Never adjust or service the tractor when it is in motion or while the engine is running. Always adjust the brake or clutch properly in accordance with the adjusting procedure in the instruction book.
6. Do not remove the radiator cap while the engine is running. Shut down the engine and wait until it cools sufficiently. For removal, turn the cap to the first stop to relieve pressure. To replace the coolant, use the coolant recovery tank.



7. Hydraulic oil or fuel escaping under pressure can penetrate the skin, causing serious injury. Before disconnecting oil or fuel lines, be sure to relieve all pressure. Before restoring pressure after repair, be sure all connections are tight and all hydraulic components are in normal condition. If injured by leaked fluid, see a doctor immediately for proper treatment.
8. When refueling, be particularly careful first to stop the engine completely to prevent the fuel from igniting. Never refuel in the presence of an open flame or while smoking. Always use funnel when adding fuel and refuel only out of doors. When refueling is completed, wipe any spilled fuel off the tractor and securely fasten the cap of the fuel tank.

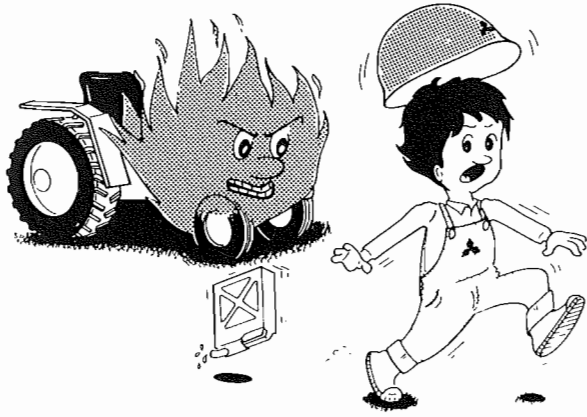

9. Before starting any work on electrical equipment or work that may cause you to touch the electrical part accidentally, first disconnect the battery cables.

Never remove the rubber cap cover at the positive terminal of the battery cable end.

Before connecting the battery to the charger, make sure that the charger switch is in "OFF" position. Be sure to connect the charger to the correct terminals on the battery, (positive to positive, negative to negative).

A great amount of hydrogen gas is generated by the battery when it is being charged. Take precautions against fire: do not have any exposed flame in the area where you are working.

Be sure not to cause any leakage of the electrolyte, since it will corrode the skin or clothing. In case of accident as described below, immediately seek first aid, and see a doctor immediately for proper treatment.

- a) If the diluted sulphuric acid from the battery has gotten into the eyes:
Cleanse the eyes with a lot of clean running water for more than 15 minutes, while opening the eyes widely.
- b) If diluted sulphuric acid from the battery has been swallowed:
Rinse the mouth with clean water immediately and drink a lot of raw eggs or milk. Lie down quietly.
- c) If diluted sulphuric acid has gotten on the skin or clothing:
Wash away the diluted sulphuric acid completely with a lot of clean running water and neutralize with soap solution. Then rinse with water.
- d) If the diluted sulphuric acid is spilled:
Wash away with a lot of water or neutralize with slacked lime or bicarbonate of soda.

- ⚠ 10. Stop the engine and make sure the PTO shift lever is in Neutral before performing any of the following services, including:
- a) Removal of the propeller shaft between PTO and any attachment,
 - b) Adjustment of PTO drive train and hitch.
 - c) Adjustment or cleaning of PTO driven attachment.
11. The steering wheel always has built-in play to some extent, which is required for smooth meshing of sector gear and pinion gear. Always inspect the amount of the play. Do not operate the tractor if there is too much or too little play in the steering.

C. OPERATION OF THE TRACTOR

Before driving the tractor, follow these rules:

C-1 Before Starting and Driving the Tractor

- ⚠ Operate the tractor only when seated properly in operator's seat and keep a firm grip on the steering wheel at all times. Never attempt to perform any operation of the tractor from anywhere else, on or off the tractor.

Always wear a "hard hat" when operating the tractor.



C-2 Starting and Driving the Tractor

Always operate the tractor at the proper speed which enables you to keep the tractor under your complete control.

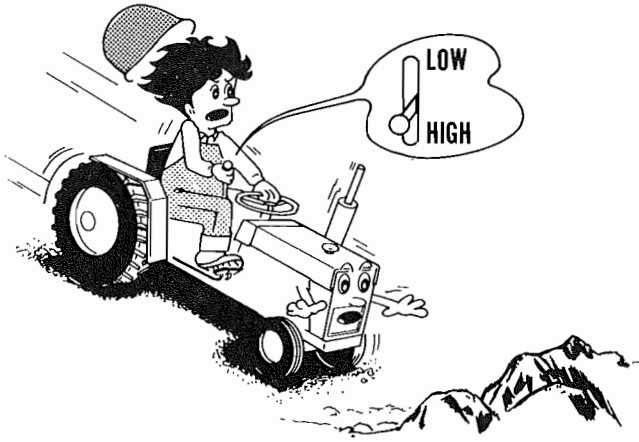

To start travelling, lower the engine speed and release the clutch pedal slowly. Abrupt releasing causes the tractor to jump off.

Before leaving the tractor, stop the engine, remove the key, apply the parking brake and make sure that the engine has come to a complete stop, and any attachment is completely touching the ground.

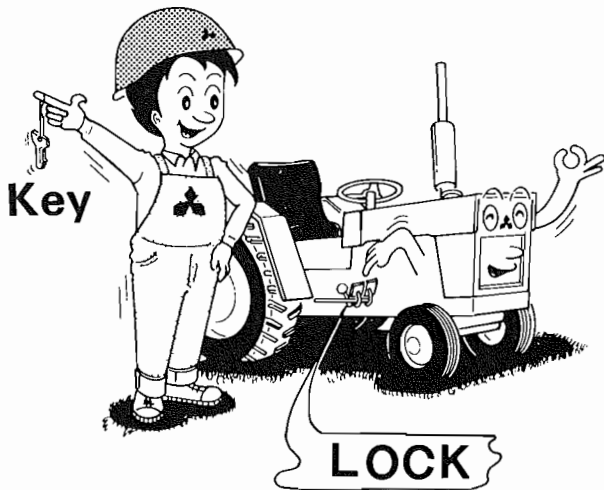

⚠ Slow down when operating the tractor on rough round.



⚠ Never attempt to jump on or off a moving tractor.

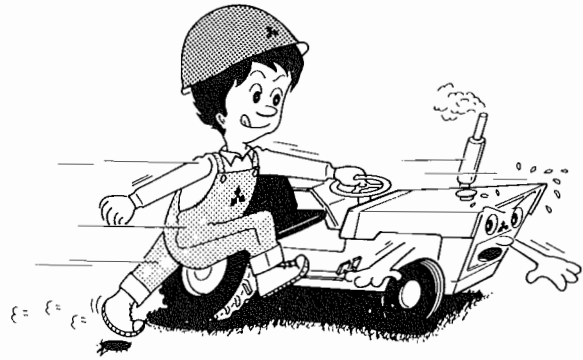

⚠ When starting the tractor, operating any attachment or engaging the PTO make sure that no one is in the way, especially children.



⚠ When starting the engine in an enclosed area or building, ensure proper ventilation by opening the doors and/or windows to prevent carbon monoxide inhalation. Mount the extension exhaust pipe on the tractor which has a cabin.

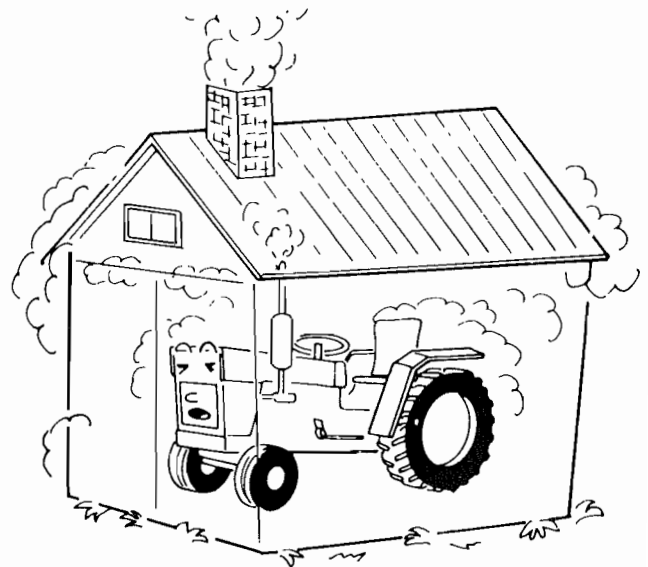

- ⚠ If the tractor is equipped with ROPS fasten the seat belt before using the tractor and keep it fastened while in operation.

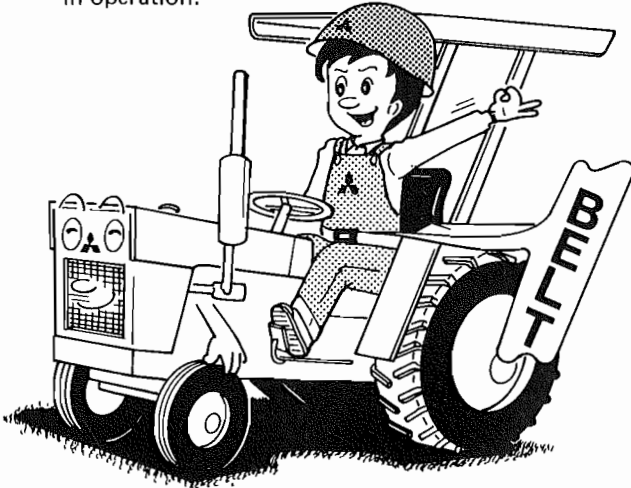

- ⚠ Use of the seat belt is not recommended for tractor without ROPS.

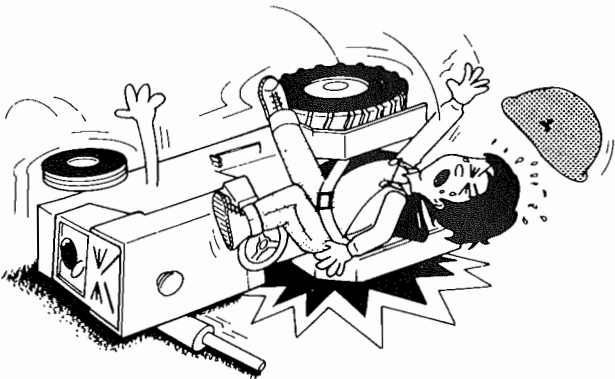

C-3 Travelling on Roads and Streets

- ⚠ For travelling on roads and streets be sure to lock both brake pedals together before driving to prevent either brake from acting independently.



- ⚠ Never operate the differential lock while driving at high speed or travelling on the road. For driving the 4-WD tractor on the road, be sure to place the 4-WD shift lever in OFF position.

C-4 Steering and Turning the Tractor

- ⚠ Slow down your tractor and disengage the differential lock before going into a turn, being careful to prevent any attachment mounted on the front or rear from hitting anyone or anything.

C-5 Towing and Operating on Hills

- ⚠ For towing work on downward slope, place the shift lever in low speed and use engine brake. Never try to reduce the speed with brake only.
- ⚠ Towing a heavy object on a hill is highly hazardous. Widen the tread of the tractor and mount the wheel weight or chassis weight to increase the stability and operate with extra caution.

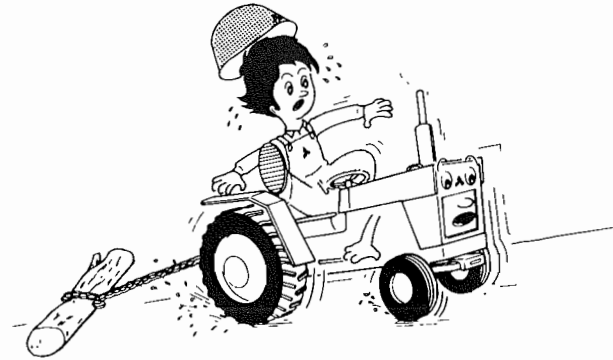

- ⚠ When operating the tractor on either a steep slope or flat ground, be sure not to suddenly steer, brake or operate clutch or attachments.
- ⚠ Do not operate the tractor at the edge of cliff or steep slope. Be particularly careful right after the rain when soil is soft and may give way easily.



For towing, be sure to use the drawbar only. Set the hitch point below the center line of the rear axle. When using a chain, never try to move forward abruptly. When using a long chain or cable to hitch the tractor to the load, drive the tractor forward slowly until all slack is taken out.

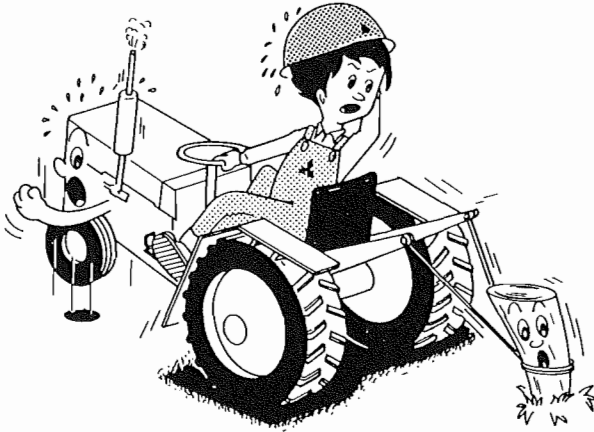

Avoid operating the tractor on an extreme slope that appears hazardous, when forced to operate on such slope, use extra care.

Driving forward out of a ditch or mired condition or up a steep slope could cause tractor to tip over rearward. Back out of such situation if possible. If the situation does not permit you to back out, use the front wheel weight or the chassis weight for balancing the tractor lengthwise. Also in case any extra-heavy rear mounting attachment is used, try to obtain better balance in this manner.

When backing down a slope in reverse gear or going up the grade in forward gear, never operate the clutch, brake, throttle lever or steering wheel abruptly. Be particularly careful on slippery roads.

⚠ In any case of towing (by use of a rope or by hanging up the front), be sure to place the both main shift lever and sub shift lever at "NEUTRAL" position so long as the rear wheels are on the ground.

* These shift levers shall not be placed at any other speed range.

⚠ When starting the engine by towing the tractor with a battery as discharged, be sure to place the main shift lever at the 3rd speed step and the sub shift lever at the high speed step, then operate the clutch slowly.

* Never place the sub shift lever at the low speed step.

⚠ When towing the tractor, be sure to keep the safety speed. It is advisable to operate at 10 km/h (6.3 mph) or less in towing the tractor under 20 HP and at 20 km/h (12.4 mph) or less in towing the tractor over 20 HP.

⚠ When towing or running on a steep downward slope, be sure to apply the engine brake to keep safety speed.

Never run by inertia (coasting) with main shift lever placed "NEUTRAL" position or the clutch disengaged.

C-6 Using Attachment

To mount or operate attachments, follow the instruction manual for the particular attachment for safe operation.



⚠ When using agricultural chemicals with an attachment on the tractor, always follow the instructions in the manual for the attachment as well as the instructions provided by the chemical manufacturer.

C-7 Roll Over Protective Structure (ROPS)

Strongly recommends a ROPS (Roll Over Protective Structure) install to your tractor. A ROPS frame is available for these tractor. Tractors can be rolled over.

⚠ Always tighten the bolts for ROPS mounting securely. Exercise good care in seat belt installation as regard belt strength and the bucket, which must not be broken off or disconnected.

For further details, ask your dealer.

SECTION 2. EXTERNAL VIEW AND NOMENCLATURE OF EACH PART

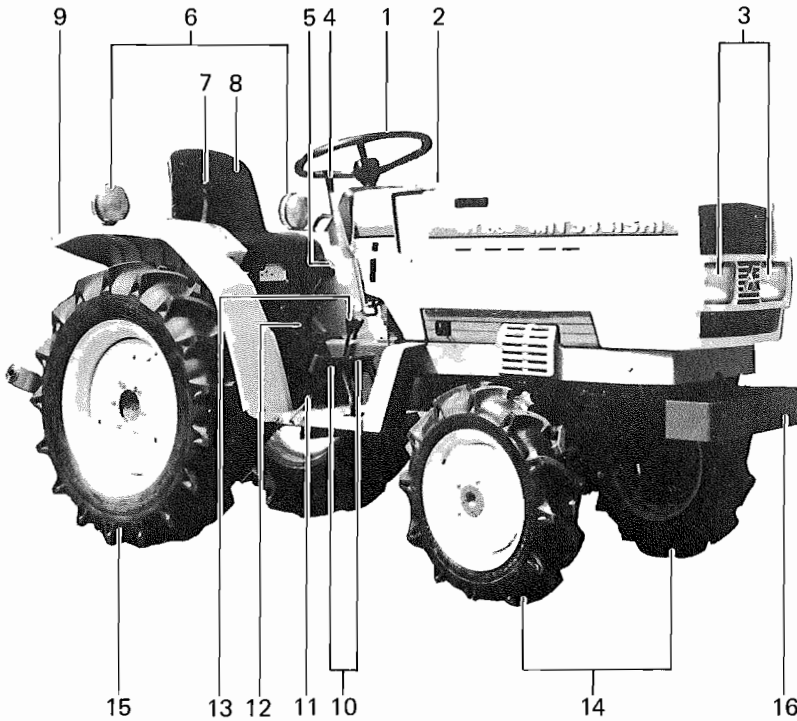

1. Steering wheel
2. Fuel tank cap
3. Head lights
4. Throttle lever
5. Main shift lever
6. Combination flash and turn signal lights
7. MT180/D . . . Position control lever
MT160/D . . . Lift, hold, down control lever
8. Seat
9. Fenders
10. Brake pedals
11. Foot speed control pedal
12. High-Low shift lever
13. 4-wheel drive shift lever
14. 4WD AG front tire
15. AG rear tire
16. Bumper

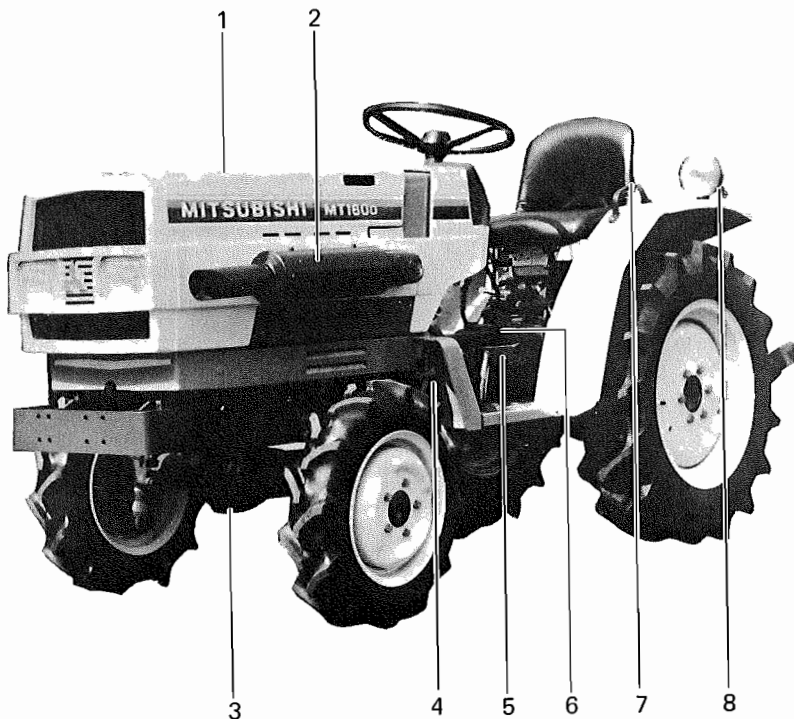

1. Bonnet
2. Muffler
3. Front drive diff. gear case
4. Drag link
5. Clutch pedal
6. P.T.O. shift lever
7. Arm rest
8. Red rear light

The above photos show MT180D (4-WD).

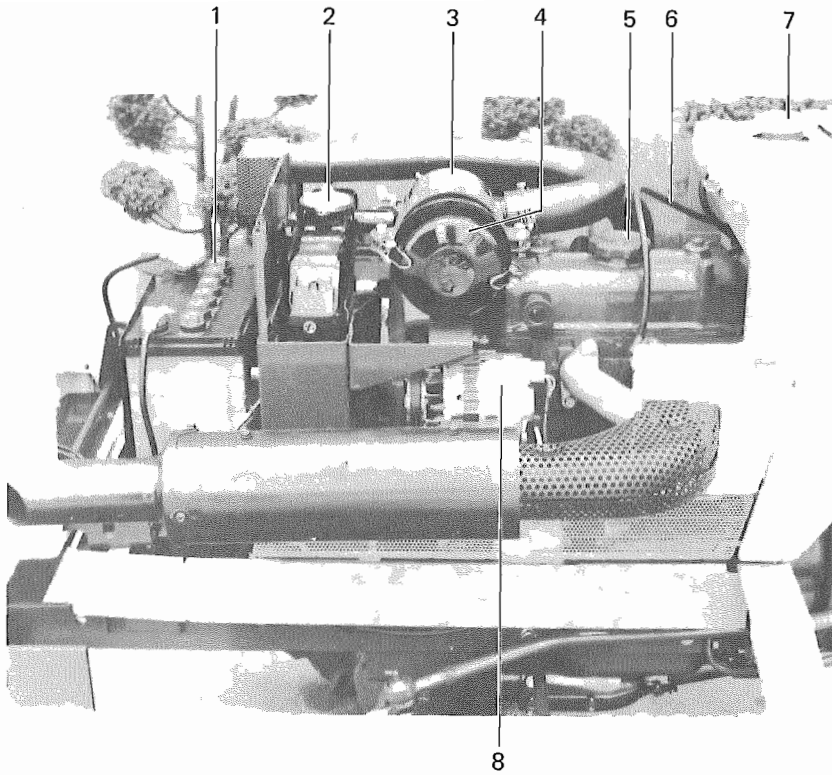

1. Battery
2. Radiator cap
3. Cyclone type air cleaner
4. Air cleaner dust pan
5. Engine oil filler cap
6. Tachometer cable
7. Fuel tank cap
8. Alternator

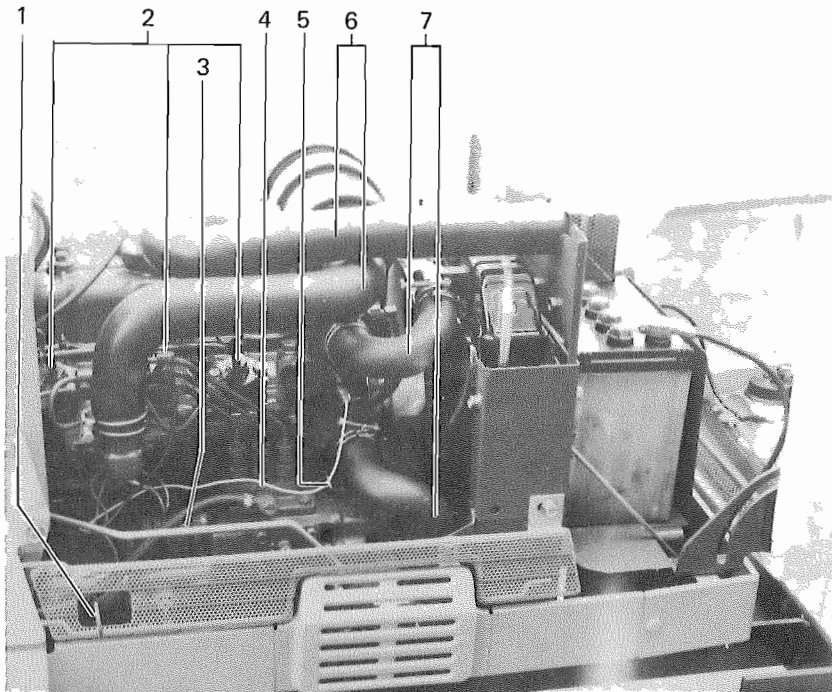

1. Engine oil level gauge
2. Injection nozzle
3. Solenoid for key engine stop
4. Fuel injection pump
5. Lead wire for water temp. warning lamp
6. Air cleaner hose
7. Radiator hose

For opening the bonnet, remove backward the hook on the rear side of the bonnet.

When closing the bonnet, be sure to confirm the bonnet is secured.

SECTION 3. INSTRUMENTS AND CONTROLS

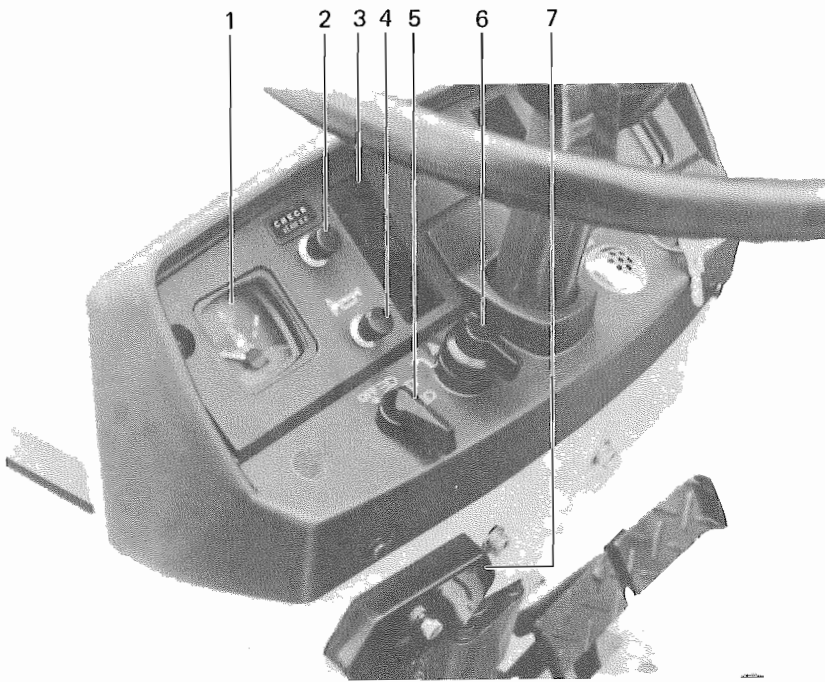

- 1. Fuel meter
- 2. Check button
- 3. Monitoring lamp unit (L.H.)
- 4. Horn switch
- 5. Light switch
- 6. Combination flash and turn signal switch
- 7. Fuse box

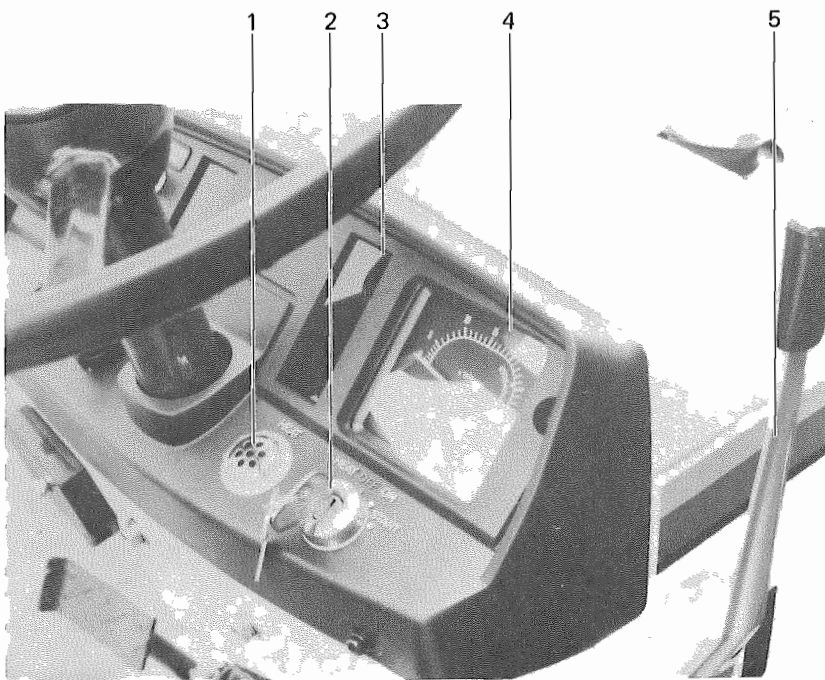

- 1. Glow signal
- 2. Key start switch
- 3. Monitoring lamp unit (R.H.)
- 4. Tractor meter
- 5. Throttle lever

KEY START SWITCH (Engine on-off key switch)

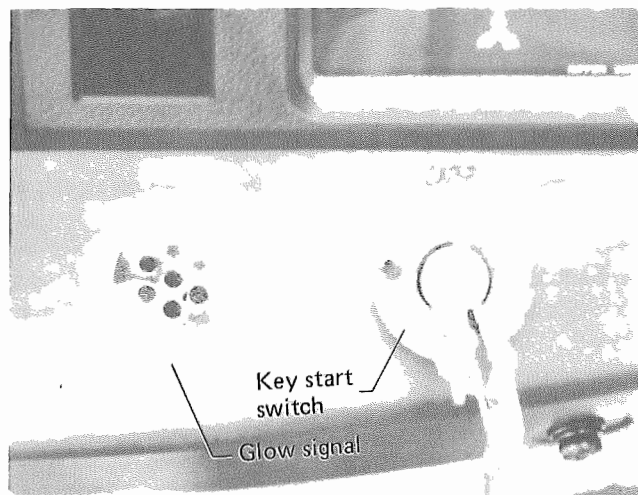

- Heat position Power applied to the glow plug
 OFF position Engine and all lights turned off
 ON position Engine running and electrical circuit energized.
- START position Starts the engine then key returns to "ON" position.

CAUTION

Be sure to remove key whenever tractor is not in operation.

GLOW SIGNAL

When the starter key is turned to "HEAT" position, internal coil glows in red indicating that the engine is preheated. The engine will be preheated in 5 sec. under normal temperature.

GLOW PLUG

The engine is fitted with speed heating sheathed glow plug which preheat the combustion chamber so that the engine may be started easily even in cold weather.

TRACTOR METER



The tractor meter indicates engine rpm.

Indication of Meter	P.T.O. shift rotation
2,340 at P.T.O. 1st shift	540 rpm
1,793 at P.T.O. 3rd shift	1,000 rpm

BATTERY CHARGE WARNING LAMP

[In the monitoring lamp unit (L.H.)]

When the starter switch is set to "ON", this lamp lights up. When the battery is being charged normally while the engine is running the lamp should go off. If the lamp continues to light, stop the engine immediately and see your Mitsubishi dealer.

OIL PRESSURE WARNING LAMP

[In the monitoring lamp unit (L.H.)]

When the starter key is switched "ON", this lamp lights up. When oil is circulating normally while the engine is running, the lamp turns off. If the lamp still lights up after the engine has been started, stop the engine immediately and check the engine lubrication oil level. If that is OK, see your Mitsubishi dealer.

WATER TEMPERATURE WARNING LAMP

[In the monitoring lamp unit (R.H.)]

When the temperature of the cooling water exceeds 110°C (230°F), the water temperature warning lamp lights up. When this occurs, lower the engine speed to about 900 rpm immediately and wait until the warning lamp goes off. Then stop the engine and check the amount of cooling water, the fan belt tension, the wiring, the temperature gauge unit and the lamp bulb.

WARNING

Be especially careful of the removal of the radiator cap.

FUEL METER



Indicates remaining fuel.

When the pointer comes over the "E" position, fill fuel as soon as possible.

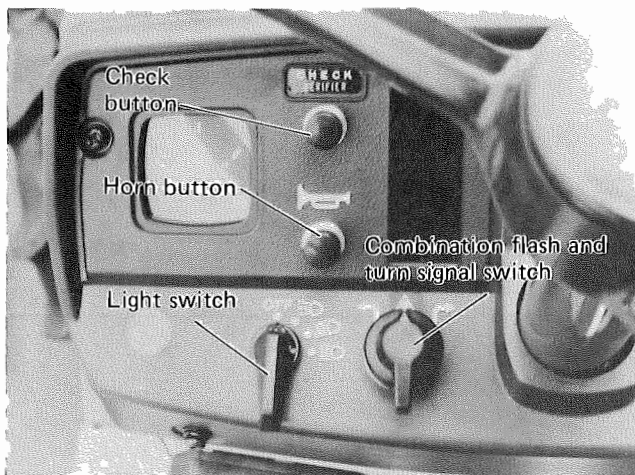
LIGHT SWITCH



The head light switch is installed on instrument panel and the operation is accomplished by turning the switch lever clockwise.

- OFF Lights are off.
-  Red tail light and meter panel lights are on.
-  Headlight are dimmed and directed downwards. low beam
-  Bright head lights. . . . high beam

CHECK BUTTON

Turn the key switch "ON" and push the check button with the engine kept stopped. Then, all the warning lamps are lighted except the turn signal lamps.

If not, ask the dealer for check.

HORN BUTTON

Horn is effective while key start switch is in "ON" position.

If not, ask the dealer for check.

COMBINATION FLASH AND TURN SIGNAL SWITCH

Two flashing lights are located on the rear of the fenders. Anytime the tractor is operated on public roads, the flashing lights should be used.

The flasher switch is installed on instrument panel and it is used when making a turn to right or left.

Turning the switch leftwise causes to flash the left-hand-side turn signal, and turning it rightwise causes to flash the right-hand-side turn signal, respectively.

Also, pulling the switch upward places the turn signals at both sides into the flashing condition.

Turning the switch in this condition leftwise causes the left-hand-side turn signal to repeat flashing and the right-hand-side turn signal to be placed in the lighted condition, while turning it rightwise causes to occur the condition just reverse to the above.

THROTTLE LEVER

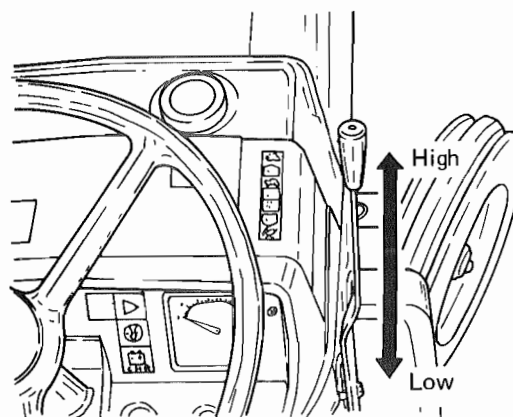

When the throttle lever is pushed forward, the engine speed reaches the maximum. The speed range controlled by the lever is 900 to 2,900 rpm (with no load). When the P.T.O. gear is shifted to "1st" at 2,700 rpm (rated engine rpm), the P.T.O. shaft rotates at 623 rpm.

CLUTCH

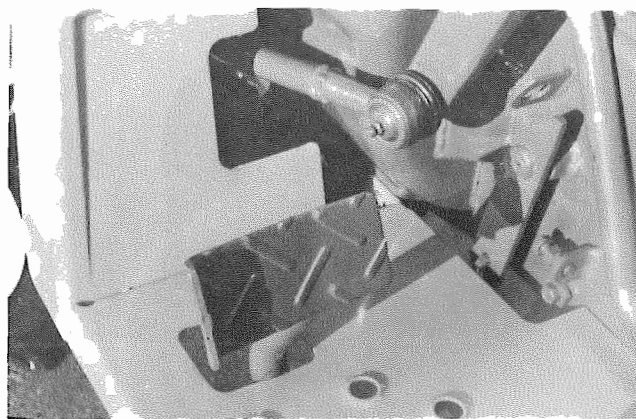

When disengaging clutch you are advised also to lower the engine speed. The life of the clutch depends on the operating habit of the user. The clutch works in combination with the P.T.O.

CAUTION

Lowering the speed, when the tractor is overloaded, by half engaging the clutch or changing gear at high speed will damage the clutch lining. Disengaging must be performed completely in one clean quick movement with the engine revolution lowered as much as possible.

NOTE

When the tractor is not used, the clutch should be disengaged by depressing the clutch pedal and the clutch lever should be hooked so that clutch linings will not get stuck.

BRAKE

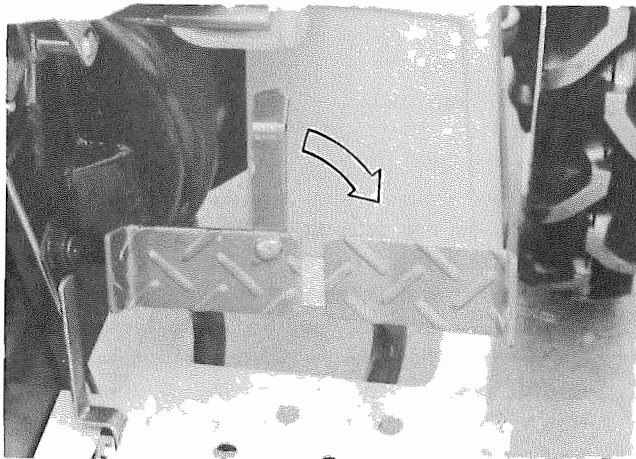

The brake is of internal expansion type and is dirt and water proof.

There are two pedals provided on the right side of the transmission case which are linked together by a plate. The brake is operated by depressing these pedals. To stop the tractor, lower the engine revolution, depress the clutch pedal and then depress the brake pedal.

For turning in a confined space the right and left axles can be braked independently by removing the plate linking the right and left brake pedals. When travelling at high speed or on roads make sure that the right and left brake pedals are linked by means of the locking plate. When starting to travel on roads after one of the brakes has been operated more often than the other, check the balance of the right and left brakes beforehand. It is necessary to check brake balance once a week. If you fail to check the brake balance or to link the right and left brake pedals, there is every likelihood that an accident will occur.

WARNING

While travelling on roads, be sure to link the both right and left brake pedals.

PARKING BRAKE

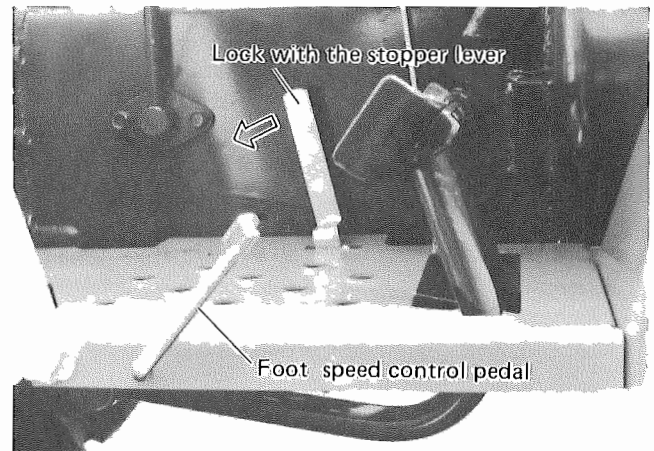

The main brake is used for parking the tractor. Connect the right and left brake pedals with the locking plate, depress the brake pedal fully and lock with the stopper lever provided beside right side of transmission case.

To release the parking brake, depress the brake pedal strongly and the parking brake is released automatically.

FOOT SPEED CONTROL PEDAL

The foot speed control pedal is installed on the right side of the step. When the hand throttle lever is in the idling position, the engine speed can be controlled freely within the range by depressing the pedal.

NOTE

When the hand speed control lever is in a high rev. position, the foot speed control pedal also moves into the position for those rev. When this is done the revolution cannot be controlled by means of the foot pedal within the range below the rev. set by hand lever.

POWER TAKE OFF

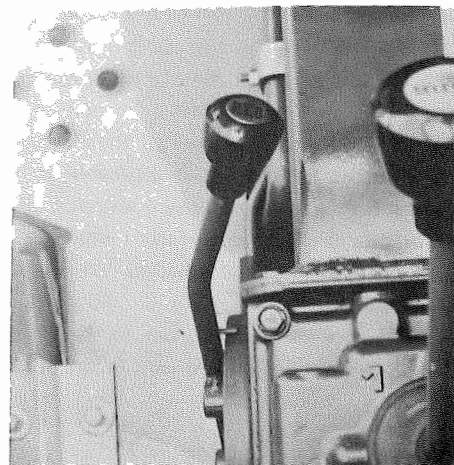

By operating the PTO shift lever located on left hand side of the transmission case, the three PTO speeds can be selected.

When shifting the PTO shift lever, lower the engine speed depress the the clutch pedal fully to interrupt the power from the engine and make sure the machine is brought to a complete halt.

First623 rpm/2,700 engine rpm
Second919 rpm/2,700 engine rpm
Third	1,506 rpm/2,700 engine rpm
Standard PTO speed.540 rpm/2,340 engine rpm
	1,000 rpm/1,793 engine rpm

WARNING

When starting the engine be sure PTO lever is in "N" (Neutral) position.

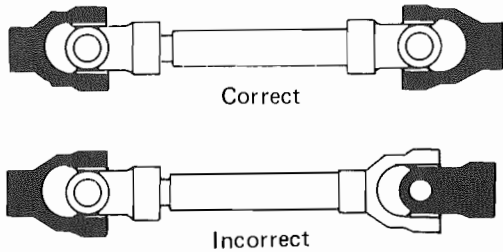

CAUTION

1. When using a rotary tiller in the field with many stones or stumps or hard soil, where a lot of shock will affect on, care should be taken so that the rotary tiller will not be damaged.
2. When using implements driven by PTO shaft, be sure to refer to implement manuals and operate them exactly as instructed.
3. When any implement is towed by the tractor, care should be taken so that the universal joint does not form an angle of more than 15°.
4. When the tractor is working with an impact load, correctly adjust the slip clutch on the implement side or use the shear pin of proper material so that the PTO is not overloaded.
5. To reduce the thrust load to the PTO driven shaft as much as possible, it is advisable to run a test operation with an implement without any load.
6. Lubricate the PTO driven shaft well.
7. Avoid using a square-shaped drive shaft where practicable.
8. Special care should be given to the yoke position so that the driven shaft is well balanced.

DIFFERENTIAL LOCK

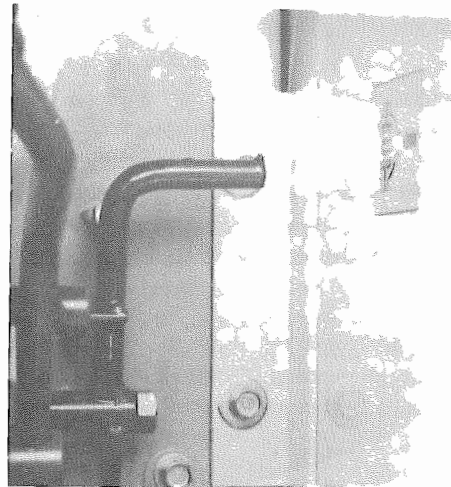

This device links the right and left wheels in the transmission and rotates them at the same speed to prevent either wheel from slipping or to increase traction force.

Engaging the Differential Lock

Before the tractor slips and the speed is lowered, depress the pedal with your right foot and engage the differential lock. If the differential lock does not engage at the first attempt, repeat the operation more forcibly. If it still does not engage, lower the engine speed and after disengaging the running clutch, repeat the whole operation as described above. If either of the left or right wheel has already begun slipping, turn the throttle lever to the idle running or disengage the clutch, then depress the differential lock pedal. Make sure that the pedal is fully depressed. The farther the pedal is depressed, the better the lock is in effect.

NOTE

Removing your foot off the pedal automatically releases it, however if it is hard to release, depress either side of brake pedal instantaneously.

How to Release the Differential Lock

Immediately after the right foot is moved off the pedal, the differential lock is automatically released by force of the spring. However, it must be remembered that the lock may not be released under special conditions. In this case, the right and left brake pedals should be quickly and alternatively depressed, then the differential lock will be set free. If the same occurs while plowing, the brake pedal of the land wheel side should be applied. The lock will be let out. When the both right and left brakes are linked for towing a trailer, operation of the steering handle to right and left allows the lock to be free. When the tractor is stopped with the differential lock applied, reverse running with a jerk can release the lock.

CAUTION

Avoid using the differential lock when operating the tractor at high speed or running on a road.

8-SPEED TRANSMISSION

The gear shift positions are as shown in the diagram below. By combination of the Main and High-Low shift levers, six forward speeds and two reverse speeds can be obtained.

The first, second, and third forward speeds and first reverse speed can be obtained with High-Low shift lever in the LOW position, and the fourth, fifth, and sixth forward speeds and second reverse speed can be obtained with the High-Low shift lever in the HIGH position.

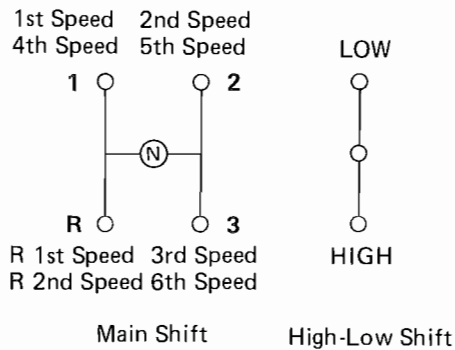
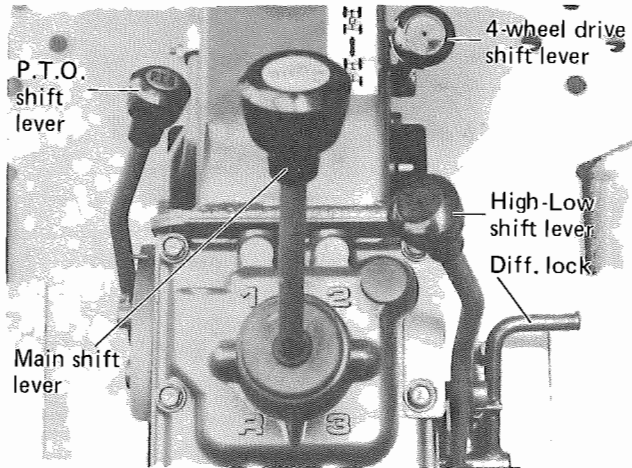

NOTE

To shift the gears, lower the engine speed and depress the clutch pedal to disengage the transmission clutch. After stopping the tractor, shift the gears.

4-WHEEL DRIVE SHIFT LEVER

The 4-wheel drive shift lever is located on the right side of the transmission case.

4-wheel drive will be engaged by pushing the 4-wheel drive shift lever forward.

With the 4-wheel drive engaged, proper power will become available for the following cases:

1. For the operation on inclined ground, wet field or sandy soil.
2. For the operation with front end loader, trailer or plow attached.
3. In order to prevent lunging forward during rotary tilling operation on hard soil.

CAUTION

1. Operate the 4-wheel drive shift lever only after depressing the clutch pedal.
2. Be sure to place the 4-wheel drive shift lever in "OFF" position for travelling on road.

SAFETY STARTER SWITCH

MT160/D and MT180/D are equipped with a safety starter switch to prevent an accident in starting the engine. By placing the High-Low shift lever in NEUTRAL, the starter switch is connected to enable to start the engine.

SECTION 4. OPERATION

BEFORE OPERATING THE TRACTOR

Before operating the tractor, read this instruction manual carefully and learn it correctly. The manual has been prepared for achieving tractor's maximum performance and safety for your work with this tractor employed.

1. Check the fuel level in fuel tank and replenish as necessary.
2. Check the levels of engine oil, transmission oil, and front drive differential.
3. Check the lubrication at every specified point on the chassis.
4. Check each bolt and nut for tightness.
5. Check the coolant level in radiator.
6. Check the fan belt tension for water pump, alternator-generator and cooling fan.
7. Check the air pressure in tires.
8. Check every indicator lamp on instrument panel for operation.

STARTING THE ENGINE

1. Open the shut off cock for fuel.
2. Keep the parking brake applied.
3. Place the main shift lever, High-Low shift lever and PTO shift lever in NEUTRAL.
4. Set the throttle lever midway between its idling and high speed positions.
5. Turn the starter key to "ON" position, push the check button to insure all warning lamps are on. And then release the button and see that oil pressure warning as well as battery charge warning lamps go on.
6. Depress clutch pedal all the way and turn the starter switch to "START" position to start the engine. (If it is difficult to start, turn the starter key to "HEAT" position and wait for about 5 seconds before restarting.)

Immediately after starting, release the starter key. The key will return to "ON" position automatically.

7. Check the oil pressure and battery charge warning lamps to see they went off. If not, stop the engine immediately and inspect.
8. Perform warm-up run at about 1,500 rpm for about 5 minutes.

CAUTION

1. Use of the starter should be limited for about 10 seconds per trial. If it is not successful, wait for about 10 seconds before another trial. Using the starter intermittently without waiting for certain period of time, can cause the battery to run down.
2. Do not turn the starter while engine is running. It can lead to the starter failure.
3. Be sure to perform the warm-up run regardless of the climate. Travelling before engine gets warm, shortens the engine life.

STARTING IN COLD WEATHER

1. The fuel injection pump of this engine adopts the mechanism to ensure easier engine start by sufficient injection of fuel when the throttle lever is fully pushed.
2. To start the engine specially in cold weather fully push the throttle lever, heat the glow plug enough and crank the engine.
3. In the temperature below freezing point, it may be necessary to use a engine block heater.

CAUTION

After the engine has started confirm that the engine is running smoothly listening carefully to ascertain if nothing abnormal sounds, and inspect for oil and water leakage.

NOTE

In case fuel runs out, be sure to bleed the fuel system after refilling the fuel tank, otherwise the engine may not be started (or even stops soon after started).

WARNING

Do not use starting aids such as Gasoline or Ether in the air intake. Explosion may result.

ENGINE BLOCK HEATER

For easier engine start in cold weather, an engine heater may be used to heat engine coolant. Contact your nearest dealer for installation.

AFTER THE ENGINE IS STARTED

1. Be sure to check the oil pressure and battery charge warning lamps to see they have gone off. If the lamp does not go off, immediately pull the throttle lever all the way backward and turn the starter key counter-clockwise to shut down the engine, and locate the cause to correct.

CAUTION

1. Particularly, by starting the engine while oil pressure is too low, serious trouble could occur because of insufficient lubrication.
2. Rotate steering wheel to see that front wheels turn to desired direction.

DRIVING THE TRACTOR

1. With the engine running, hold the tractor with the brakes if necessary.
2. By pulling hydraulic control lever backward, raise the implement.

WARNING

Raise or lower the implement with sufficient caution against any obstacle around.

3. Bring the engine speed to about 1,500 rpm (warm-up run).
4. Depress clutch pedal all the way.
5. Move each shift lever to desired position.
6. While travelling, interlock left and right brake pedals with locking plate so that they are applied simultaneously.

⚠ WARNING

For travelling at high speed, interlocking the left and right brakes is particularly essential. Be sure not to travel at high speed with left and right brakes being independent to each other (not being interlocked).

7. Do not attempt to stop tractor using brakes, which may cause failure of transmission internals or premature wear of brake linings.
8. To avoid damaging brake or transmission system, be sure to release the parking brake before travelling.
9. While increasing the engine speed gradually, release the clutch pedal slowly.

⚠ WARNING

1. Release the clutch gradually. Releasing it suddenly is hazardous causing the tractor to lunge.
2. Before travelling backward, be sure to check for any obstacle behind the tractor.
3. For travelling on public road or working at high speed, be sure to lock the left and right brake pedals with locking plate so that both brakes are applied simultaneously.
4. During high speed operation or travelling on road, do not use differential lock. The 4-wheel drive shift lever and PTO shift lever should be placed in "OFF" and "NEUTRAL" positions respectively.
5. While travelling, remove your foot off the clutch or brake pedals.
6. Independent use of left or right brakes should only be allowed for low speed operation.

⚠ CAUTION

For travelling with 3-point linkage attached, tie it with belt or the like for prevention of swinging of the lower link.

7. If any implement is mounted, turn the tractor slowly paying particular care for the space.
8. Do not make a sharp turn at high speed. Be sure to lower the engine speed before turning.
9. Before starting the operation on slope, check for the existence of stone, irregularity, rutting or other dangerous factors which could lead to an accident. Avoid the operation on steep slope as it can be a cause of tipping over.
10. On the downhill, use engine brake. Do not place the main shift lever in "NEUTRAL" position.
11. For towing use a draw-bar only. Set the hitch point below the center line of the rear axle.

STOPPING THE TRACTOR

1. By pulling throttle lever, reduce engine speed.
2. Depress clutch pedal all the way.
3. Keep the brake depressed until the tractor comes to a complete stop.
4. Move PTO shift lever to NEUTRAL.
5. Move main shift lever to NEUTRAL.
6. Remove foot off the clutch pedal slowly.
7. Stop the engine by starter key turned to OFF position.

8. Apply parking brake.
9. Push hydraulic control lever slowly forward to lower implement to ground.
10. Remove the key.
11. Close fuel shut off valve above fuel filter.

⚠ CAUTION

1. Be sure to always apply the parking brake while the tractor is in parking or standing.
2. Select flat and level ground for parking.
3. Apply blocks to rear wheels on the slope.

TREAD ADJUSTMENT

FRONT:

4-wheel drive front tread is as shown below.

	MT160	MT180
AG tire	785 mm (30.9 in.)	785 mm (30.9 in.)
ES tire	800 mm (31.5 in.)	800 mm (31.5 in.)

MT160

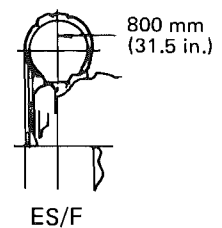
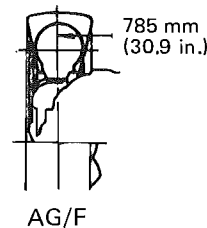

MT180

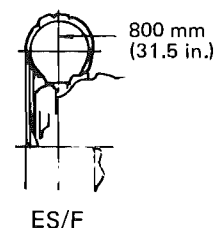
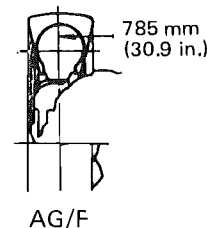

2-wheel drive front tread is as shown below.

	MT160	MT180
AG tire	720 mm (28.3 in.)	720 mm (28.3 in.)
ES tire	790 mm (31.1 in.)	795 mm (31.3 in.)

MT160

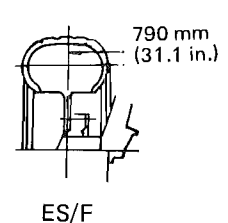
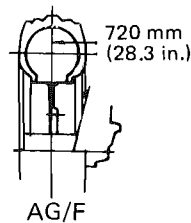

MT180

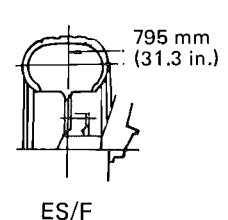
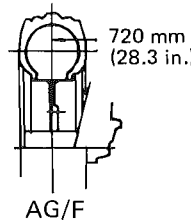

NOTE

1. Axle housing and gear case tightening torque
6 ~ 7 kg-m (43 ~ 50 ft-lb)
2. Front tire tightening torque
4-WD 8.5 ~ 9.5 kg-m (61.4 ~ 68.6 ft-lb)
2-WD 12.0 ~ 13.5 kg-m (86.7 ~ 97.5 ft-lb)

REAR:

The rear tread can be adjusted by changing the left and right wheels to each other. This adjustment is applicable to either specification – of 2-WD or 4-WD and ES or AG tire.

2-WD and 4-WD tread

	MT160		MT180	
	Standard tread	Max. tread	Standard tread	Max. tread
AG tire	740 mm (29.1 in.)	890 mm (35.0 in.)	740 mm (29.1 in.)	890 mm (35.0 in.)
ES tire	790 mm (31.1 in.)	840 mm (33.1 in.)	770 mm (30.3 in.)	865 mm (34.1 in.)

Rear wheel tightening torque. 12.0 ~ 13.5 kg-m
(86.7 ~ 97.5 ft-lb)

MT160

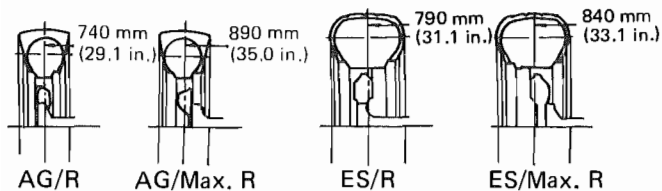

MT180

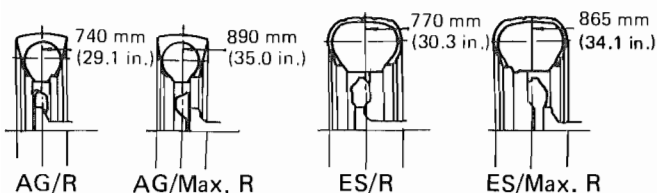

CAUTION

1. Avoid widening front tread of the 2 and 4-wheel drive tractor by switching the right and left front tires as this may cause serious troubles on the steering linkage.
2. Check at frequent intervals to make sure that the rear and front wheel are tightened securely to specified torque and that the axle housing and gear case are secured each other to specified torque.

REAR WHEEL INSTALLATION

Make sure that rear tires are mounted so that the lugs on the tire form the staggered V's in series as viewed from the front of the tractor.

BALLAST WEIGHT

The slipping not only damages the tire but also results in working inefficiency and greater fuel consumption. Slipping, therefore, must be minimized as much as possible. For that purpose, ballast weights are available as optional equipment. It is recommended that the tractor be provided with ballast weights when working in the place where slipping is likely to occur. The ballast weights can be attached on rear wheel discs and the front of the chassis. Ballast can also be applied by putting water into the tires instead of using the ballast weights. For this operation, pay particular attention to the temperature and air pressure.

In cold weather where the temperature drops below 0°C (32°F), use water with antifreeze and never fill the tire with only water. It is of course possible for you to employ a combination of water in the tire and ballast weights. Consult your dealer concerning the water injector and method of injection.

Rear wheel weight: 2-WD and 4-WD AG & ES

33 kg (72.8 lb) x 2 = 66 kg (145.5 lb)

Chassis weight: 2-WD and 4-WD

20 kg (44.1 lb) x 1 = 20 kg (44.1 lb)

TIRE PRESSURE

Tire pressure should be checked frequency. Either too high or too low pressure results in deterioration of the tire. To properly maintain the tires, make sure that the tire pressure is checked at least once a week.

MT160

	Tire size	Ply	Std. pressure	Valve type
AG	Front 2-WD	4.00-9	2.0 kg/cm ² (28.4 psi)	TR-13
	Front 4-WD	5-12	2.0 kg/cm ² (28.4 psi)	TR-13
	Rear 2 & 4-WD	8-16	1.0 kg/cm ² (14.2 psi)	TR-15
ES	Front 2-WD	18x7.00-8	2.0 kg/cm ² (28.4 psi)	TR-413
	Front 4-WD	6-12	1.5 kg/cm ² (21.3 psi)	TR-13
	Rear 2 & 4-WD	9.5-16	1.0 kg/cm ² (14.2 psi)	TR-15

MT180

	Tire size	Ply	Std. pressure	Valve type
AG	Front 2-WD	4.50-10	2.0 kg/cm ² (28.4 psi)	TR-13
	Front 4-WD	5-12	2.0 kg/cm ² (28.4 psi)	TR-13
	Rear 2 & 4-WD	8-18	1.0 kg/cm ² (14.2 psi)	TR-218A
ES	Front 2-WD	20x8.00-10	1.5 kg/cm ² (21.3 psi)	TR-413
	Front 4-WD	6-12	1.5 kg/cm ² (21.3 psi)	TR-13
	Rear 2 & 4-WD	9.5-18	1.0 kg/cm ² (14.2 psi)	TR-218A

NOTE

Air pressure of the tires must be changed according to the loading weight on the tires. For more details, please call and talk with local dealer.

OPERATOR'S SEAT



It is adjustable spring supported seat in 3 stages at increment of 30 mm (1.18 in.) to suit to the operator's stature.

TOOL BOX

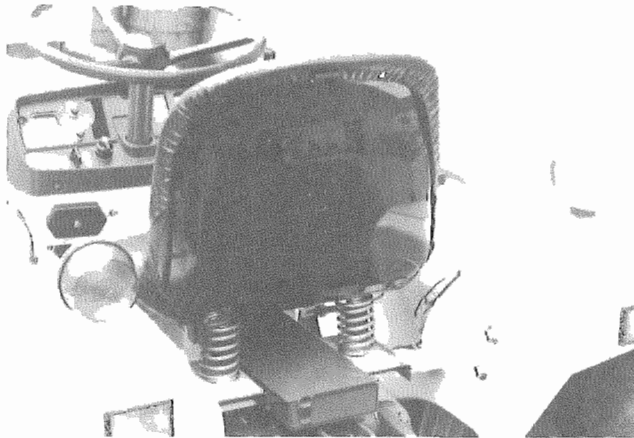

The tool box is located under the operator's seat. To use the tool box, turn the seat downward to the front.

DRAWBAR

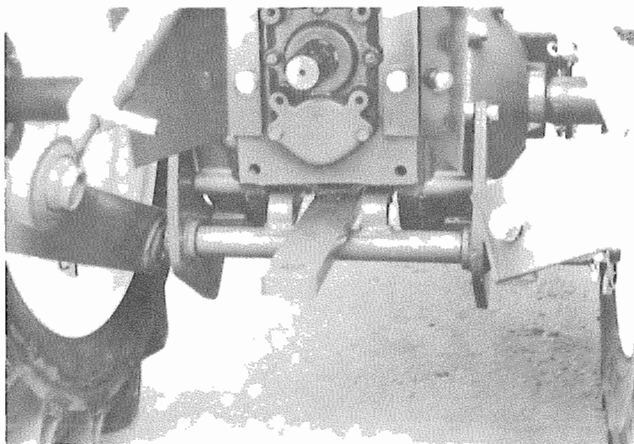

The fixed type drawbar is provided as standard. To tow an attachment or trailer, be sure to use the drawbar.

3-POINT LINKAGE

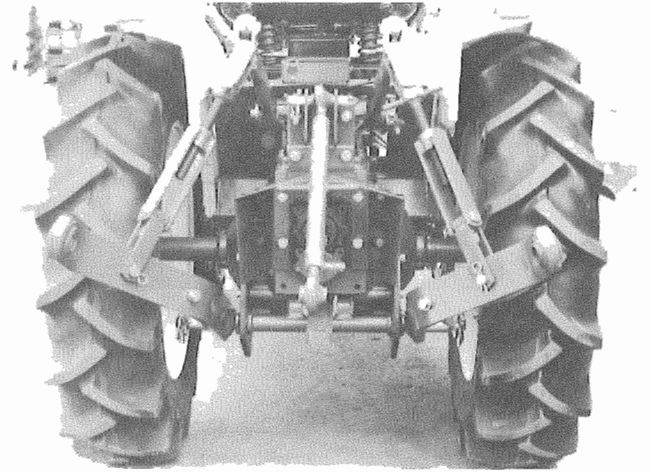

This tractor is provided with a 3-point linkage of category 1.

The implement which is to be mounted, must match the 3-point linkage.

NOTE

When an implement is towed with the linkage drawbar installed on lower links, the lower links should always be kept horizontal.

HYDRAULIC SYSTEM

Your tractor is provided with the live hydraulic system in which a hydraulic pump is driven directly by the engine camshaft and always makes the oil circulate to exert the hydraulic pressure while the engine is running.

The hydraulic oil of exclusive use is reserved in the transmission case and passed through the oil filter, thus ensuring effective operation.

Position control, flow control (down speed control) and lock of the implement are possible with the hydraulic control lever installed on the right side of the seat.

For external service, the hydraulic pressure can be taken out by fitting an adapter plate to the delivery pipe installed on the left side of the seat.

POSITION CONTROL

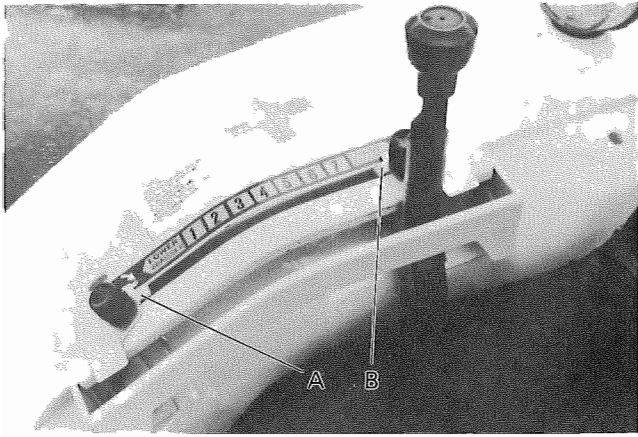

Position control is provided for determining and holding the position of an implement as desired by means of a lever. Normally it is utilized for the work employing rotary tiller, broadcaster, mower or rake. To use the position control, operate the control lever in the following manner:

- Pulling the lever backward will cause an implement to rise.
- Pushing forward will cause an implement to lower by its own weight.
- Placing the lever at certain position, causes implement to move to and stop at the height corresponding to the position of the lever.
- For holding the height of the implement at certain position constantly, use stopper A to fix the lever position, which will make the lowered position of an implement to be maintained at the constant height.

CAUTION

Stopper B is provided to prevent the hydraulic safety valve from being actuated. Be sure not to move it for any purpose other than hydraulic power take off. For returning the displaced stopper B to its original position, first operate the position control lever in upward direction, then from the position where actuating sound of the safety valve starts, slide the stopper B downward by 5 to 8 mm and tighten it there.

FLOW CONTROL KNOB

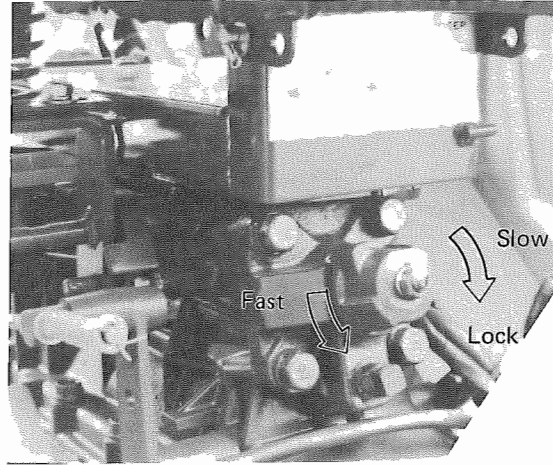

MT160/D and MT180/D provide the flow control knob which controls the lowering speed of the implement. It is located in front of the hydraulic case under the seat.

When the knob is turned clockwise, the lowering speed slows down, and when further turned, the control valve is closed. As a result, the implement will be held in its position and will not move downward any further. Turning the knob counterclockwise increases the lowering speed.

NOTE

Adjust the lowering speed according to the type of an implement and operating condition.

Rotary tiller operation Lowering speed – Slow
Plow operation Lowering speed – Fast

WARNING

1. For travelling on the road, be sure to turn the flow control knob all the way clockwise and lock it there.
2. During tine replacement, or grass or straw removal of rotary tiller, or during inspection of implement, for the safety, place the position control lever in upward position, shut down the engine and be sure to lock the flow control lever.

EXTERNAL HYDRAULIC SERVICE

The hydraulic pressure can be used to control the implement installed to the tractor.

NOTE

When taking out the hydraulic pressure, be watchful of oil level in the transmission case and sticking of the pump to be caused by oil shortage.

POWER TAKE OFF FOR FRONT LOADER (Option)

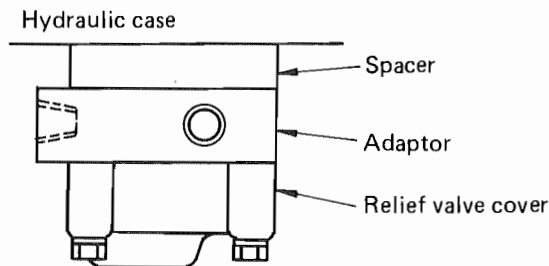

For the power take off for the front loader, install a spacer and an adaptor, fastened to each other, between the power take off on the left side of the hydraulic case and relief valve cover.

Control valve and operating lever is provided with the implement.

NOTE

1. For any implement other than this front loader, if it is provided with a control valve, use this power take off. However, it can not be used at the same time with the front loader.
2. For installation of the front loader, consult with your local dealer.

WARNING

1. For operating the front loader, etc., do not place the hydraulic control lever of the tractor at "RELIEF" position as it may cause trouble in the hydraulic system.
2. For safety, during the front loader operation, have the rotary tiller installed. The rotary tiller should be raised all the way with the flow control knob set at its lock position so that it will not be lowered.

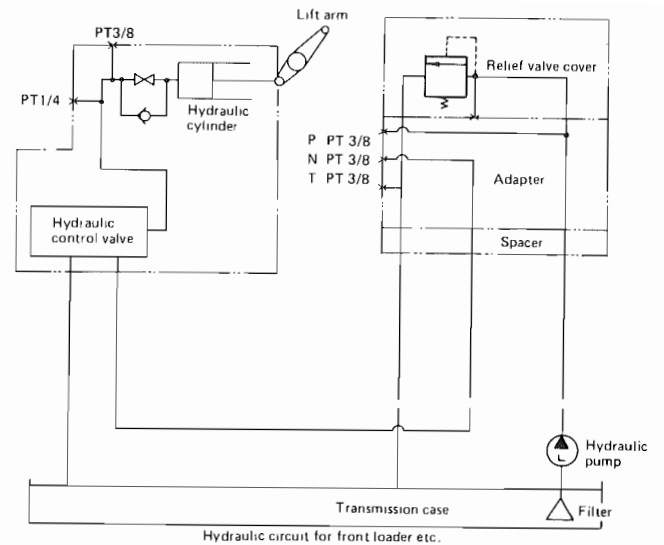

P.T.O. GUARD

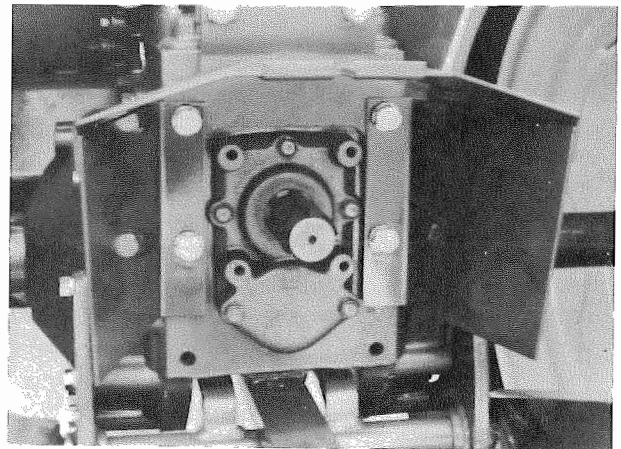

In any type of operation, be sure to install the PTO guard for additional safety.

SECTION 5. REGULAR MAINTENANCE GUIDE

To keep your tractor operating in the top condition and to assure its proper performance and reliability for a long period of time, periodic inspection is indispensable. If your tractor is not periodically serviced, the result will be such that its performance and operating life will be reduced. Also a major breakdown is more likely to occur, which will entail much more expense what you would pay for regular maintenance.

Maintenance and servicing are very important, however, the procedure is very simple. Carry out daily checking, greasing and periodic service by carefully following the instructions given in this manual. In addition to daily inspection the following servicing must be carried out:

50-hour service to be carried out on a new tractor.

A-serviceService every 50 hours
 B-serviceService every 100 hours
 C-serviceService every 200 hours
 D-serviceService every 400 hours

NOTE

The tractor should always be kept clean. Before greasing or removing the oil pan plug and filter cap, be sure to wipe the surface clean. When using tools for repairing inside the engine, transmission, fuel tank or hydraulic unit, clean the tools before use. Be careful especially when refueling. If dust or water gets in the fuel, engine trouble will be experienced, resulting in loss of power and the unexpected necessity of parts replacement. The tractor should be serviced indoors where there is plenty of room and it is as clean as possible.

SERVICE SCHEDULE

Observe the following service schedule. This service schedule is applied to tractors which are operated under normal conditions. When your tractor is frequently operated in muddy places, greasing must be carried out more frequently and when the tractor is often operated in dusty places, clean the air cleaner element and fuel filter more frequently. Extra servicing must be carried out according to particular situation.

SERVICE SCHEDULE CHART

Hours of operation	A-service	B-service	C-service	D-service
50	○	○		
100	○	○		
150	○			
200	○	○	○	
250	○			
300	○	○		
350	○			
400	○	○	○	○

* After completing the first 400 hours of operation, repeat the service schedule given in the above chart.

* Usually B service is carried out in every 100 hours. For a new tractor, however, B service should be carried out at the time of 50 hours service too.

DAILY INSPECTION

1. Check for leakage of oil, water or fuel and repair the part as necessary.
2. Check the engine oil, transmission oil and cooling water. If the level is not proper, replenish.
3. After finishing work, replenish with fuel up to within 25 mm (1 in.) below the fuel tank filler cap.
4. After working in dusty places, clean the air cleaner element. Remove dried grass etc. from the radiator front and clean the radiator and radiator screen.
5. Tightening nuts and bolts
Tighten the front and rear wheel fixing bolts. All other nuts and bolts should be firmly tightened.
6. After working in a muddy place, grease the king pins, front axle center pin and brake shaft via the grease nipples provided.
7. Check the tire pressure and adjust if necessary.
If it is not as specified make necessary adjustment.
8. Check the brake and clutch pedals for correct free play. If it is not as specified make necessary adjustment.
9. All moving portions must be cleaned and lubricated with engine oil so that they work smoothly.
10. Check the electrolyte level in the battery, and if it is below the specified level add distilled water.
11. Check the fan belt tension and if it is slack adjust it.

A-SERVICE (Every 50 hours of operation)

NOTE

1. A new tractor needs good attention. Following should be read carefully to understand all the things to be done.
2. Some items described here are the same as for daily inspection but special care should be given to them when carrying out the 50 hours service.

50-HOURS SERVICE FOR A NEW TRACTOR

1. Replace the engine oil filter and engine oil.
2. Replace the transmission oil.
3. Retighten all bolts and nuts, paying special attention to those of steering linkage and wheel.
4. Check and adjust the fan belt tension.
5. Check the wheels to see if their condition is good and tire pressure is correct.
6. Retighten the cylinder head bolts and adjust valve clearances.
7. Front axle diff. case and gear case oil replacement for 4-wheel drive tractor.
8. Cooling water replacement.
9. Clean the air cleaner element.
10. Clean the fuel filter.
11. Check the front hub for end-play.
12. Check the battery electrolyte for its level and specific gravity.
13. Clean the hydraulic oil filter.

50-HOUR SERVICE FOR OTHER THAN NEW TRACTOR

1. Cleaning the air cleaner element
Blow compressed air to inside of an element and clean it thoroughly. If the element is remarkably dirty, wash it with a neutral detergent. Wipe off or blow off with air the dust on the dust pan and body.
2. Clutch adjustment
Adjust the clutch pedal so that there is correct amount of free play.
3. Cooling water replenishment
Check that the specified quantity of cooling water is entered and if not, fill with water up to within 25.4 mm (1 in.) below the filler cap. The full amount of cooling water cannot be supplied in one operation. When cooling water has been completely drained, fill with new water, then run the engine at low revolution for a short period and then fill to the specified level again.

Check the water hose for damage and inspect connections for leaks.

NOTE

In cold weather, check the specific gravity of the antifreeze water mixture.

4. Tightening nuts and bolts
Tighten all nuts and bolts because vibration is always noticed when the tractor is operated. At the same time, check the ballast weight bolts for tightness.
5. Greasing
See "Greasing diagram".
6. Check the front hub for end-play.
7. Washing the fuel filter.
8. Inspecting and replenishing with the electrolyte in the battery.

B-SERVICE (Every 100 hours of operation)

1. Replacing the engine oil.
The engine oil should be replaced at the first 50 hours service and again replaced after another 50 hours of operation. Thereafter, replace the oil every 100 hours of operation.
2. Replace the engine oil filter with a new one.
3. Check the specific gravity of the battery electrolyte.
4. Clean the fuel filter.

NOTE

Carry it out at the same time as DAILY INSPECTION AND A-SERVICE.

C-SERVICE (Every 200 hours of operation)

Carry out as follows along with DAILY INSPECTION, A-SERVICE and B-SERVICE:

1. Replace the transmission case oil.
2. Clean up the hydraulic oil filter.
3. Replace the oil in the front axle differential case and the front gear case of the 4-wheel drive tractor.

D-SERVICE (Every 400 hours of operation)

Carry out as follows at the same time as DAILY INSPECTION, A-SERVICE, B-SERVICE and C-SERVICE.

1. Replace the air cleaner element.
The element is usually replaced in every 400 hours, but, for different operating conditions, judge the timing of the replacement by inspecting the element.
2. Replace the cooling water.
3. Clean the outside of the radiator.
4. Check the valve clearance.
5. Check the injection nozzle.
Check the nozzle condition and injection pressure.
6. Replace the fuel filter.

No.	Items	Maintenance Interval								Thereafter every
		50	100	150	200	250	300	350	400	
1	Engine oil replacement	●	●		●		●		●	100
2	Engine oil filter element replacement	●	●		●		●		●	100
3	Fuel filter element cleaning-up and replacement	○	○		○		○		●	100 400
4	Air cleaner element cleaning-up and replacement	○	○	○	○	○	○	○	●	○ 50 ● 400
5	Injection nozzle pressure check								⊕	400
6	Transmission oil check or replacement	●	⊕		●		⊕		●	● 200 ⊕ 100
7	Hydraulic oil filter element cleaning-up	○	○	○	○	○	○	○	○	50
8	4-WD front axle diff. case and front gear case oil check or replacement.	●	⊕		●		⊕		●	● 200 ⊕ 100
9	Valve clearance check	⊕							⊕	400
10	Cooling water check or replacement	●	⊕	⊕	⊕	⊕	⊕	⊕	●	200
11	Specific gravity of battery electrolyte check	⊕	⊕		⊕		⊕		⊕	200

-Replacement
-Cleaning-up
- ⊕Check

NOTE

The intervals shown in the above chart regarding replacing, cleaning-up and checking are for the standard. Perform each service so as to meet the requirement depending upon the operational condition of the tractor.

Application	Kind of Oil	API Classification	Ambient Temperature	Grade (SAE No.)		Description
				Single	Multi	
Engine	Motor oil or Super tractor oil universal (STOU)	CC CD	~ 10°C (14°F)	5W	5W-20	Use High grade oil of famous brand.
			-20 ~ 0°C (-4 ~ 32°F)	10W	10W-30	
			-10 ~ 10°C (14 ~ 50°F)	20W		
			0 ~ 20°C (32 ~ 68°F)	20		
			10 ~ 30°C (50 ~ 86°F)	30	20W-40	
			30°C (86°F) ~	40		
Transmission/Hydraulic, 4-WD Front Axle.	Gear Oil	GL-3 or better	Below 0°C (32°F)	75W	-	Use good grade oil of famous brand.
			-10 ~ 30°C (14 ~ 86°F)	80W	80W-90	
			0 ~ 35°C (32 ~ 95°F)	85W	85W-140	
			10°C (50°F) & above	90		
	OR * Farm tractor use transmission/hydraulic oil or multi-service fluid.			All seasons		
Steering gear oil	Grease	-	NLG1 - No. 1		Not requiring periodical service. Replace only when overhauling.	

GREASING DIAGRAM

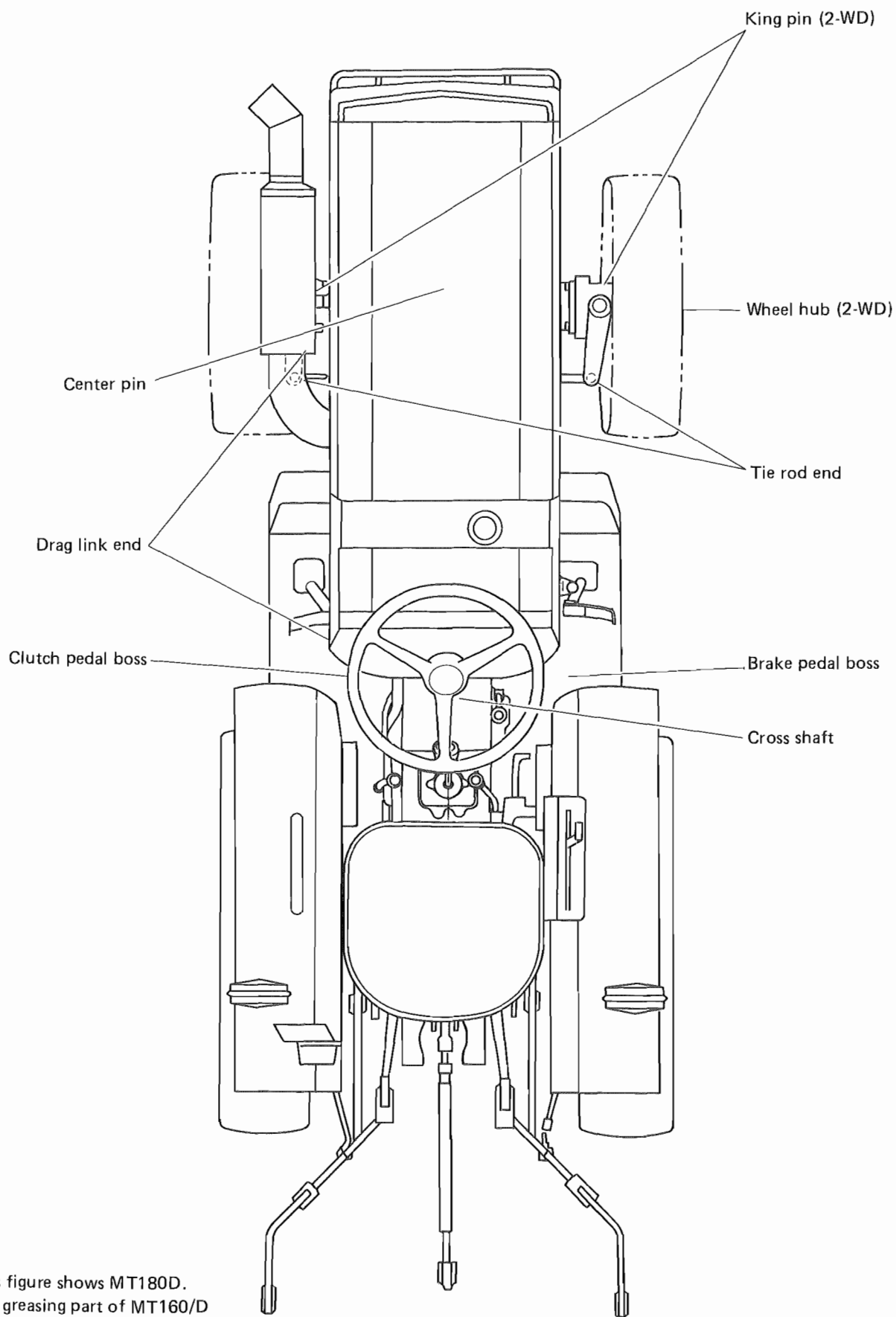

This figure shows MT180D.
The greasing part of MT160/D
is same as MT180/D.

- ① King pin (2-WD)
- ② Wheel hub (2-WD)
- ③ Center pin
- ④ Tie rod end

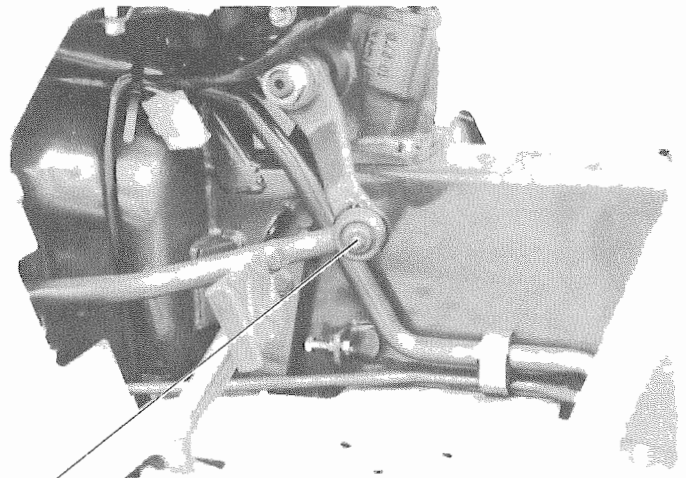
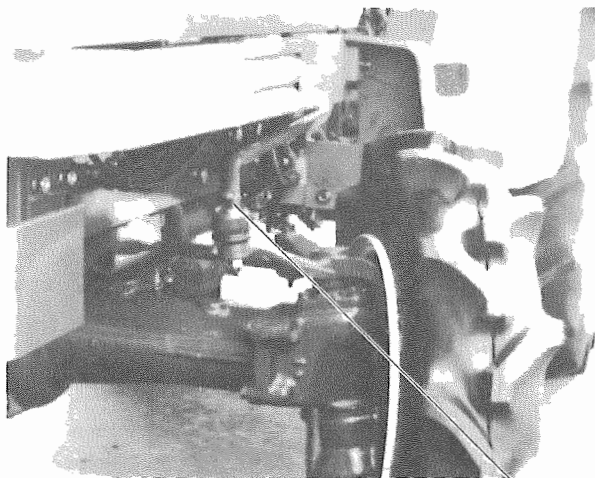
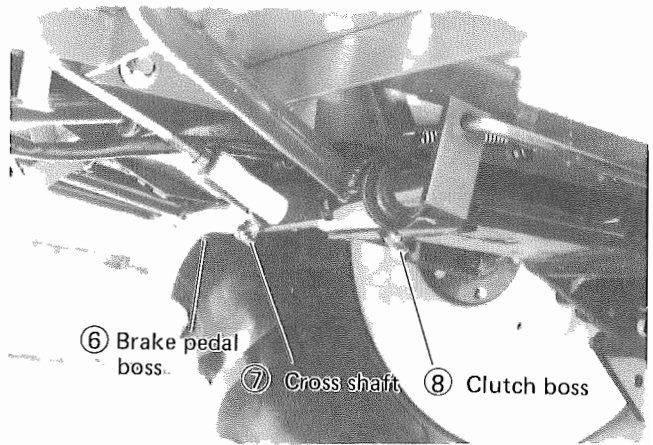
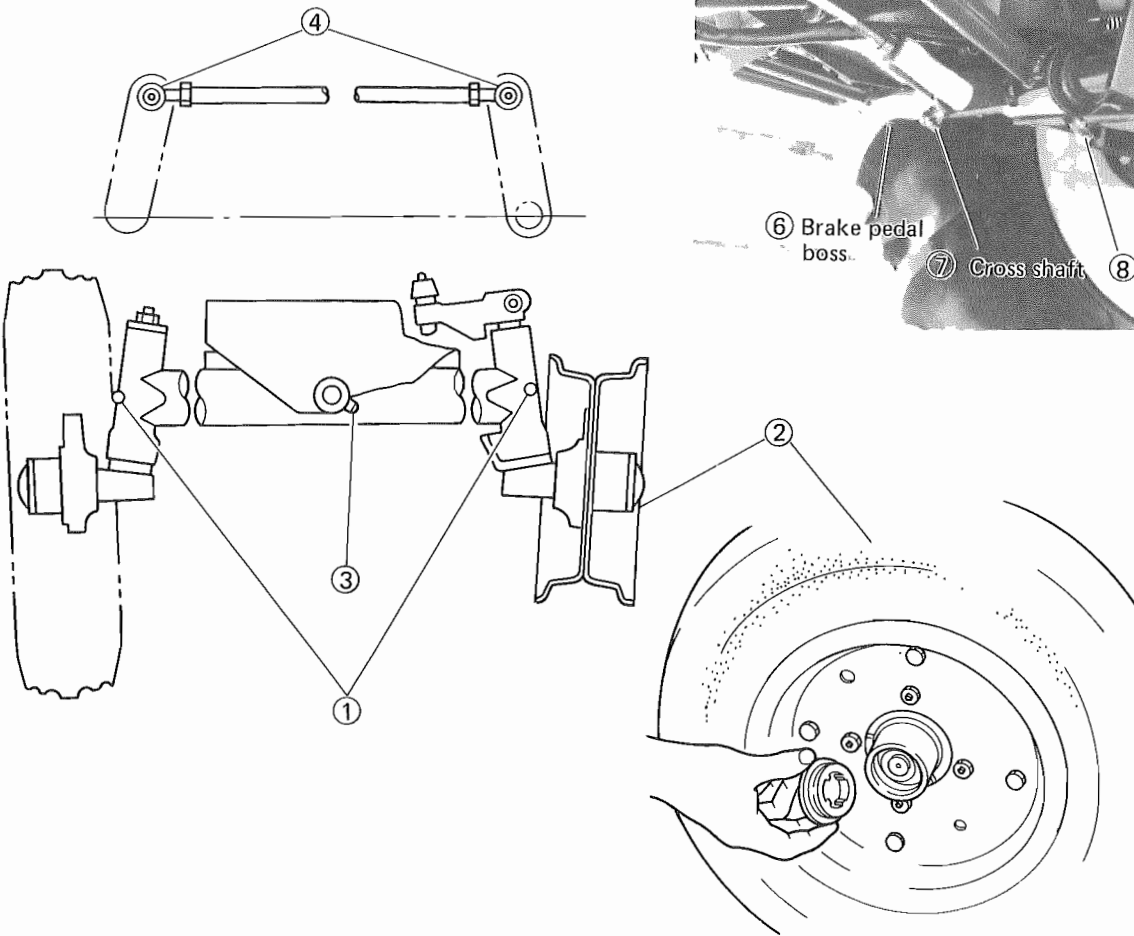

⑤ Drag link end

SECTION 6. PREVENTIVE SERVICE INSTRUCTION

This section provides servicing instruction required for regular maintenance and adjustment and its procedures.

NOTE

When carrying out the maintenance services or adjustments, place the tractor on as open and level ground as possible. Before removing caps, plugs, and covers, wipe clean the surrounding surfaces so as not to allow dust or dirt to enter inside of the engine and the tractor.

HOOD AND SIDE COVERS OPENING/CLOSING

Before opening the hood for pre-start inspection or light servicing, push a knob at the hood rear in the direction of the arrow marked on knob.

CHECKING THE RADIATOR COOLANT LEVEL

Remove the radiator cap to see if the coolant is upto the filler port.

CAUTION

1. Use clean soft water only.
2. River water, etc. may cause rust, corrosion or clogging in the radiator or engine.
3. See paragraph "ANTIFREEZE" for its use.

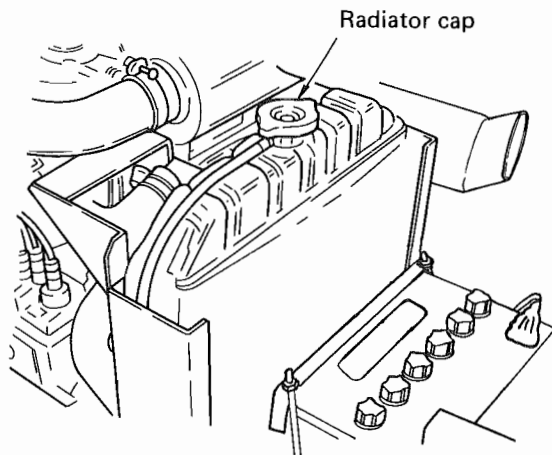

WARNING

Do not remove the radiator cap except for checking the coolant level or coolant replacement. Removing the cap immediately after operation is hazardous because pressurized hot water will jet out. Stop the engine and wait until it cools down before removing the cap.

COOLANT REPLACEMENT

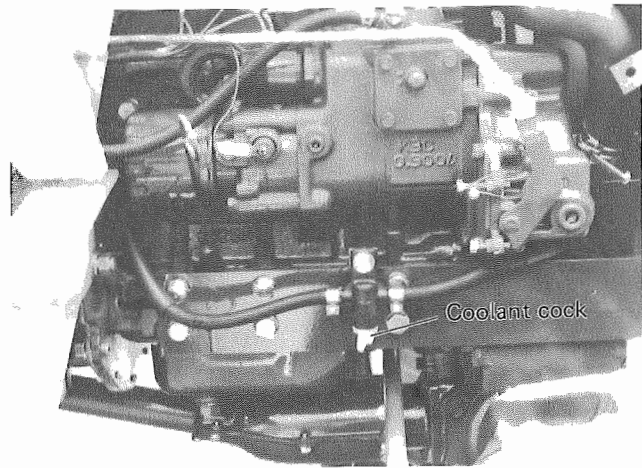

- Loosen the coolant cock at lower right of the engine and drain the coolant.
- For replenishment, remove the radiator cap and enter water upto the radiator filler port.

WARNING

Be sure to loosen the coolant cock only while the engine is cool.

PRECAUTIONS ON COOLING SYSTEM IN COLD WEATHER

Frozen cooling water may damage the cylinder block. To avoid such a trouble, mix antifreeze into cooling water, or thoroughly drain cooling water from the cylinder block in case the tractor is stored or left unused for a long time in cold weather.

ANTIFREEZE

When adding antifreeze solution, the following rules should be observed, otherwise, the cylinder block will rust.

1. This tractor's engine is of a diesel type and its cylinder block is made of cast iron. Therefore, suitable anti-freeze solution for such a cast engine block must be used.
2. Before adding mixture of antifreeze and water, completely drain cooling water and clean the radiator with detergent.
3. Water to be added to antifreeze should be clean soft water.
4. When antifreeze is no longer used, drain and wash the cooling system using detergent and fill it again with clean water. Do not re-use antifreeze drained from the engine.

5. Treat antifreeze carefully so that it may not remove paint from the cylinder block.
6. Any antifreeze solution (antifreeze and water), even if it is permanent antifreeze, should not be used for more than 2 years.
7. Confirm that there are no leak from the hose connections or cylinder head gasket.
8. Antifreeze with proper density to suit the climate in your area should be used.
9. When antifreeze is used over a long period in winter, measure the specific gravity frequently.

NOTE

Consult your dealer concerning detergent and anti-freeze.

FUEL SYSTEM AIR BLEEDING

If fuel is exhausted and the engine stops or when the fuel filter element is cleaned, air is induced into the fuel line. In such case, the fuel system must be bled after refilling the fuel tank. If air remains in the fuel line, the engine cannot be started.

FUEL FILTER AIR BLEEDING

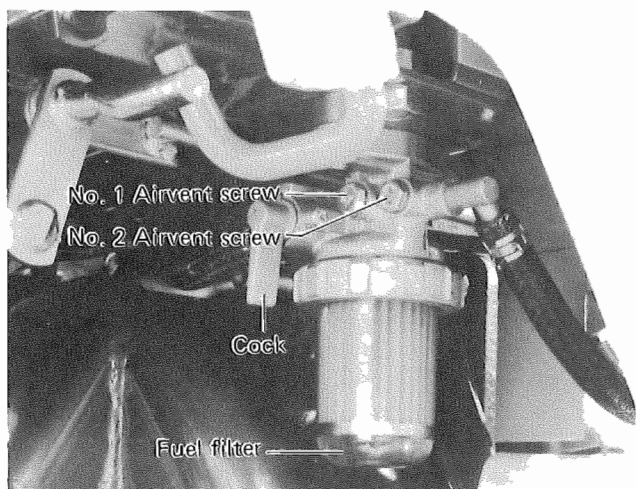

Fill the fuel tank up to proper level. Loosen No. 1 air vent screw shown in the above photo and tighten it up after filling with fuel until no air is noticed. Then loosen No. 2 air vent screw, fill with fuel until no air is noticed and tighten up the air vent screw in the same manner.

FUEL PUMP AIR BLEEDING

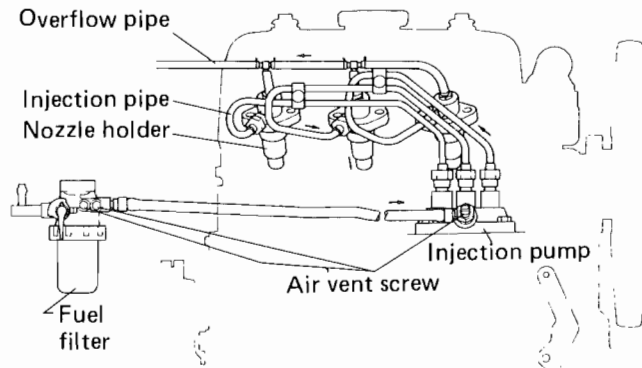

Loosen the air vent screw of the fuel pump to let the fuel to overflow after fuel filter air bleeding. When no more air bubbles is noticed in the fuel, tighten the screw.

NOTE

With this operation, the engine should start, but if not, bleed the injection pipe.

FUEL PIPE AIR BLEEDING

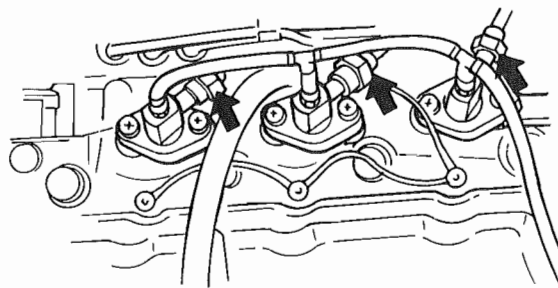

Loosen the nut of the injection nozzle as shown above and shift the throttle lever to high speed position. Then, start the engine by operating the starter motor and make sure the fuel is discharged properly at the loosened nozzle connection. Tighten the nut to the specified torque. Start the engine according to the steps given in "OPERATING THE TRACTOR".

NOTE

Unless air is completely bled, the engine can not be started; in such case, perform air bleeding again to let remaining air completely out of the system.

FUEL FILTER ELEMENT REPLACEMENT

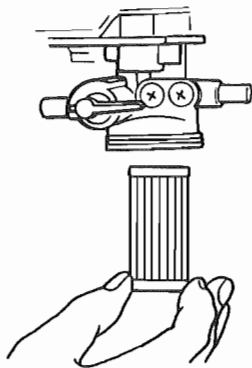

Fuel filter element is inserted in the filter body in the cup. To replace the element, close the filter body cock, loosen the ring nut and remove the cup. After removing the element, clean it or replace it, as necessary. After installing the cleaned or new element to the filter body, install the cleaned cup to the body with care about "O" ring and then tighten it enough. Loosen the air vent screw, open the cock, fill the cup with fuel, and after confirming there is no more air left, tighten the air vent screw, ensuring there is no fuel leakage.

NOTE

In case the engine won't start, loosen the fuel pump air vent screw and purge it.

CLEANING THE FUEL TANK

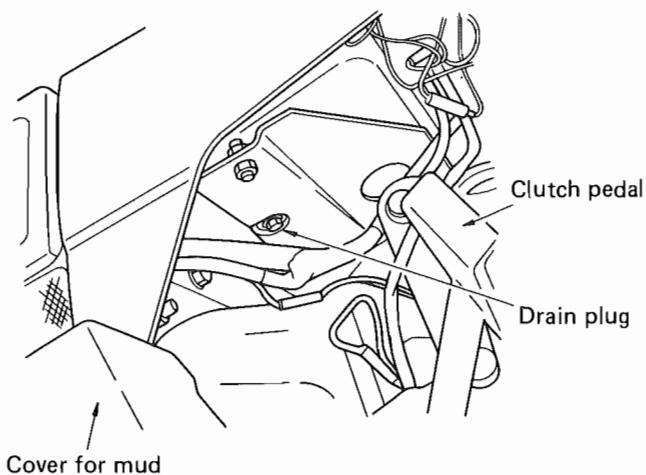

Remove drain plug and clean the tank in the following cases.

1. Every 600 hours of operation.
2. In case kerosene was entered for cleaning purpose, or water or dirt is in the tank.

CHECKING THE ENGINE OIL LEVEL

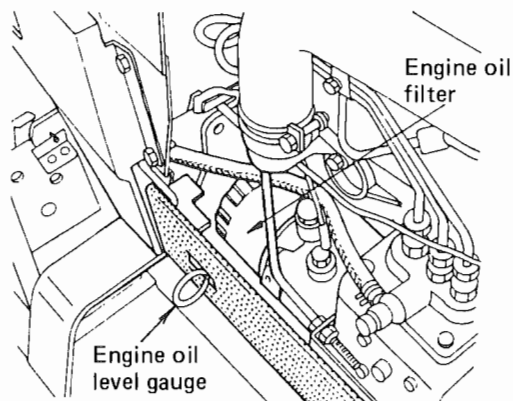

The level is appropriate if it comes between two markings at the end of gauge rod. The level should be checked before starting the engine or 5 minutes after the engine stopped.

NOTE

Check the oil level with the engine stopped in any event.

ENGINE OIL REPLACEMENT

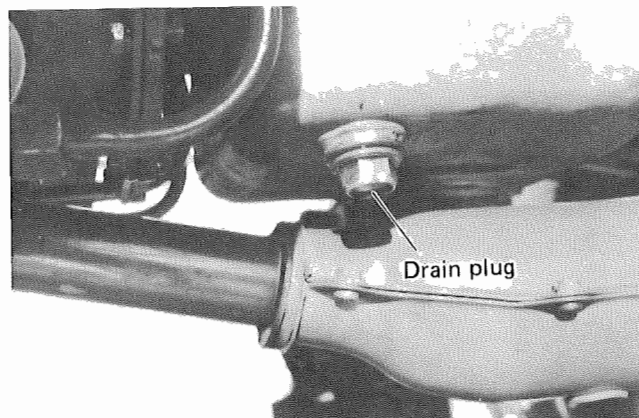

Remove the plug of the engine oil pan and completely drain the used oil. Supply the specified oil up to the specified level. It should be noted that dirty oil is more easily discharged when it is warm.

Replacing the engine oil should be carried out while the tractor is placed horizontally.

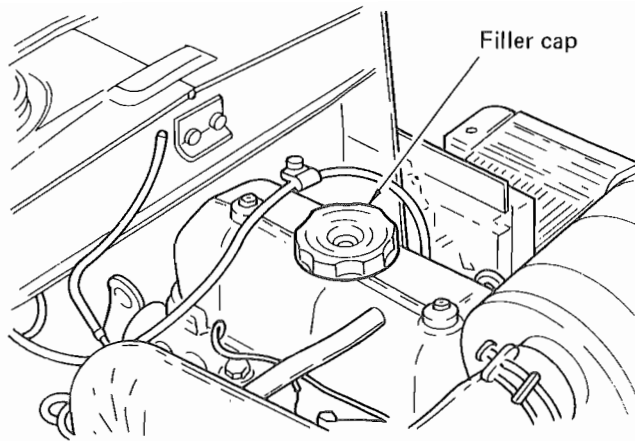

Fill with new oil from filler port. Make sure that the filler cap is tightened securely before starting the engine.

ENGINE OIL FILTER REPLACEMENT

When necessary, the cartridge type engine oil filter should be removed with the special tool, and replaced with a new filter.

NOTE

1. Lightly apply the engine oil or grease to the seal surface of the oil filter before mounting.
2. After the oil filter has been screwed in and the rubber seal comes in contact with the case surface, screw in the filter 2/3 turn further by hand.
3. After mounting, start the engine and inspect the seal surface for leaks.
4. Replacing the filter causes the oil to be reduced by the volume of the filter. Recheck the oil level after running the engine for 5 minutes.

INJECTION NOZZLE INSPECTION

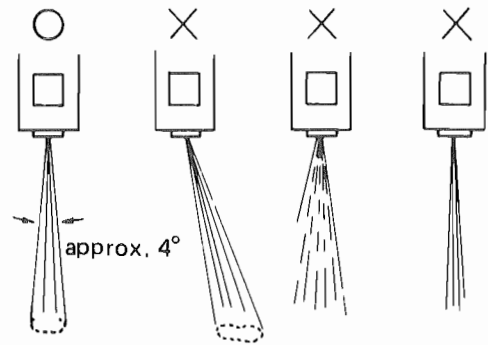
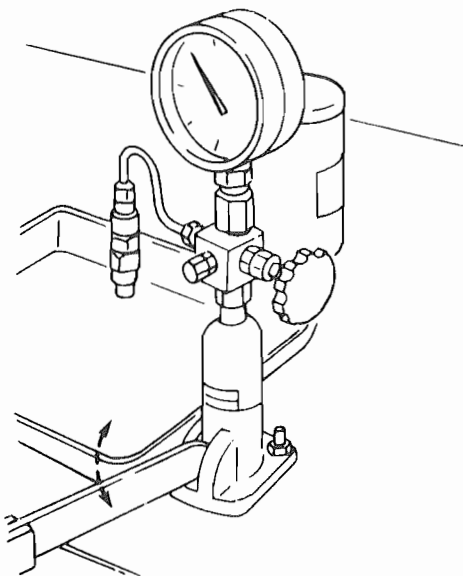

When the injection pressure of the nozzle is lowered or injection deteriorates, the exhaust gas becomes extremely black resulting in the loss of engine power and the engine will also make greater noise. Be sure to always maintain the correct injection pressure of 120 kg/cm^2 (1,706.97 psi).

CYLINDER HEAD BOLT TIGHTENING

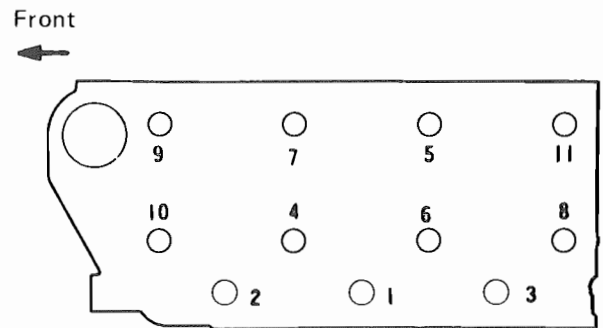

Tighten the cylinder head bolts of a new tractor after 50 hours of operation. When the old gasket has been replaced with new one, tighten the bolts to the specified torque.

Tightening torque of the cylinder head bolts:

M10 7 ~ 8 kg-m (51 ~ 58 ft-lbs)

M12 11 ~ 12 kg-m (80 ~ 87 ft-lbs)

Bolt tightening sequence is as shown in the Figure. For uniform tightening of the bolts, the first tightening should be for half the specified torque and then tighten it further until the specified torque is reached.

NOTE

After tightening the cylinder head bolts, adjust the valve clearances.

VALVE CLEARANCE ADJUSTMENT

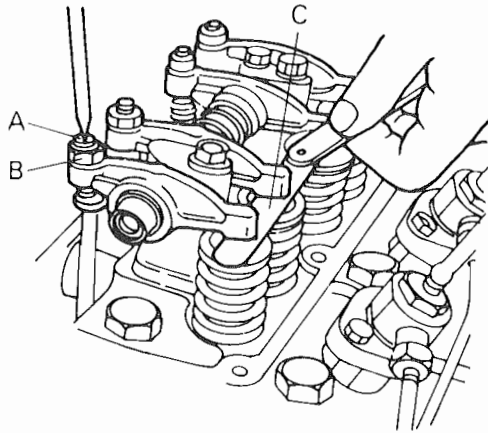

Adjust the valve clearances when the sound of the tappets is loud or when the engine does not run smoothly without anything abnormal with the fuel system.

Adjust the valve clearances by loosening the lock nut (B), the adjusting screw (A) using a screwdriver and then applying a thickness gauge to (C). When locking the adjusting screw by means of the lock nut (B), support the adjusting screw firmly using a screwdriver so that both are not rotated together.

Valve clearance: Intake & Exhaust
0.25 mm (0.01 in.) in cold condition.

VALVE CLEARANCE ADJUSTMENT PROCEDURE

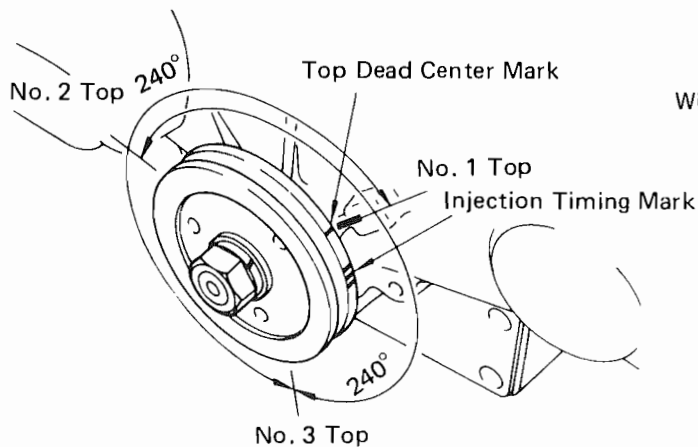

1. The valve clearance should be checked with a cold engine and with the piston at top dead center on the compression stroke.

The top dead center on the compression stroke of No. 1 piston can be determined by the timing marks on the crank pulley and timing gear case.

2. Position the piston in No. 1 cylinder at top dead center on compression stroke and adjust its intake and exhaust valve clearance.
3. Then rotate the crankshaft 240 deg. clockwise to move the piston of No. 3 cylinder to top dead center on compression stroke, and adjust its valve clearance.
4. Then rotate the crankshaft 240 deg. clockwise to move piston of No. 2 cylinder to top dead center on compression stroke, and adjust its valve clearance.

AIR CLEANER

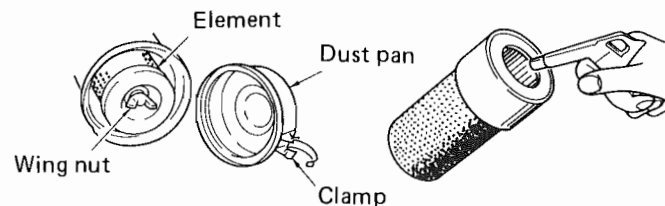
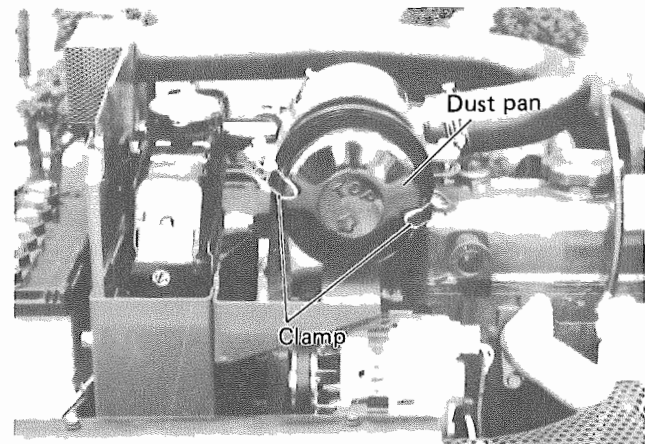

The air cleaner element, when remarkably stained or clogged, may prevent smooth start of the engine or deteriorate its performance, preventing normal operation. Keep the element always clean to ensure full performance of engine.

Clean the element in the following procedure:

1. Remove the dust pan clamp and take out the dust pan. Clean the separator plate ass'y and dust pan.
2. Unscrew the wing bolt and take out the element. Blow the compressed air to remove dust completely. Blow out the dust from the inside of the rubber seal and tap hole.

- The element may be washed in synthetic detergent. After washing, rinse the element completely and dry before mounting. Never use it before drying up completely.
- Be careful not to allow the dust in the body ass'y and on the pressure-fitted surface of the element seal to enter the air hose. Disconnect the air hose when cleaning the cleaner body by blowing the air.

Assembling the element

Assemble the element to the body and fasten with the wing bolt completely. Assemble the separator plate ass'y to the dust pan ass'y and install it to the body ass'y taking care of the top mark.

NOTE

- When operating in extremely dusty conditions, service the filter more frequently than specified.
- Clean the element with compressed air below 7 kg/cm^2 (100 psi).

FAN BELT TENSION ADJUSTMENT

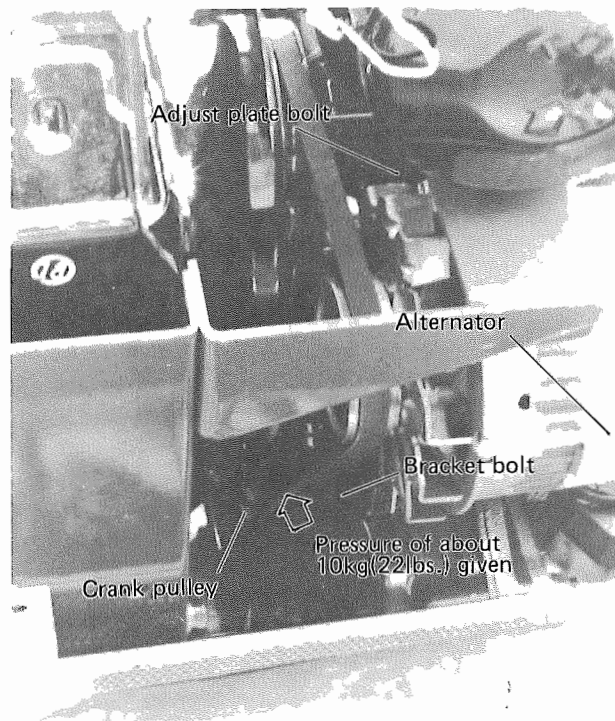

Proper fan belt tension is for 10 ~ 12 mm (0.4 ~ 0.5 in.) deflection with a thumb pressure applied halfway between the crank pulley and alternator pulley. To adjust the tension, loosen the alternator bracket bolt and the adjust plate bolt and move the alternator in or out. After proper tension is obtained, tighten the bolt securely. Check the belt for cracks and damages.

BATTERY (OUTSIDE NORTH AMERICA)

The battery equipped is POLYMION battery, model NX100-S6L (S). Though small-sized, it shows 40% higher performance as compared with conventional batteries of the same size.

- The specific gravity of electrolyte is $1,280 \pm 0.010$ at 20°C (68°F).

NOTE

Shipment for North America does not contain battery. Read battery manufacturer's manual and follow.

CAUTION

When the battery is not used for a long period of time in cold weather, check the specific gravity and charge the battery periodically.

- The level of electrolyte should be between the lower and upper levels indicated on the outside of the battery case. Particularly in hot weather, frequently check the level of battery electrolyte.
- In order to prevent the development of rust or other corrosion at the battery terminal, coat the terminal lightly with lubricant.
- Before demounting the battery, be sure to shut down the engine and turn off all the electrical switches. Battery cable at earthing end (negative terminal end) should be disconnected first.
- For cleaning the terminal stud, first remove the battery cable then use a wire brush for brightening it.
- For the reinstallation of the battery, make sure to set it on the battery support properly.
- For connecting the battery cables, connect \oplus end of it first, followed by earthing end.

CAUTION

The electrical system is of negative earth type. Care should be taken to ensure that the battery terminals are correctly connected when installing the battery.

- For dependable battery service, see your local dealer.

BOOSTER CONNECTION

In case the battery has run down making it impossible to start the engine, the booster is used for starting the engine using good battery of the other vehicle (12V specification vehicle) as power source. Following procedure should be observed in such case:

PROPER PROCEDURE FOR BOOSTER CONNECTION

CORRECT CONNECTION

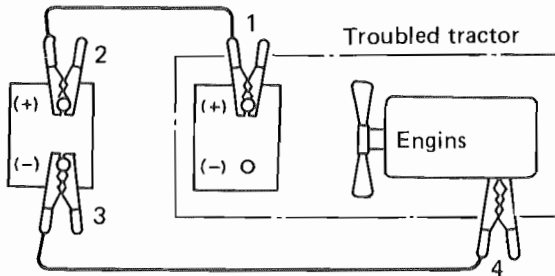

1. Before connecting the booster, carefully check the followings to see:
 - That the spring in the cable clip is normal.
 - That cable or clip is not broken or corroded.

CAUTION

Select a booster cable with as large a capacity as possible.

2. Stop the engine of the vehicle (source side) which is in normal operation.
3. Connect a clip of the booster cable (in red) to \oplus terminal of the battery on the troubled vehicle and firmly connect another clip to \oplus terminal of the normal vehicle.
4. Then connect a clip of another booster cable (in black) to \ominus terminal of the normal vehicle and finally connect another clip firmly to the engine block.

WARNING

Do not fail to perform in above order.

During the final connection, spark will be generated. Therefore, connect the \ominus clip to the engine block at as far away point from the battery that is generating gas as possible.

Before connecting the cables, remove the electrolyte port plugs where possible, because as long as such plugs have been removed, the explosion will be smaller even if it may catch fire resulting in smaller damage.

5. Start the engine on the troubled vehicle.
If the engine is difficult to start, try to start it after starting the engine of the normal vehicle.

PROPER PROCEDURE FOR REMOVING BOOSTER CABLES

CORRECT DISCONNECTION

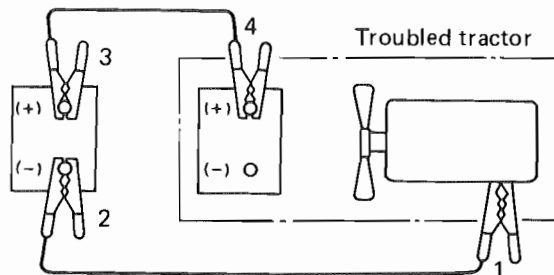

After the engine is started, remove the booster cables in the reversed procedure of above.

1. First remove the \ominus end clip from the engine block of the troubled vehicle, then remove another clip from the \ominus terminal of the normal vehicle.
2. Then remove a clip from \oplus terminal of the normal vehicle, followed by removal of another clip from the \oplus terminal of the troubled vehicle.

PROPER BATTERY SERVICE AND TIPS FOR SAFETY

Work	Item	Proper servicing	Tips for safety	Check electrolyte	Watch for explosion
Inspection	Electrolyte level	If low Replenish	Watch for soiling with leaked electrolyte	○	
	Specific gravity	If below 1.200 (20°C) . . . Charge	○ Watch for splashing the electrolyte. ○ See "Battery Recharging".	○	
	Battery tester	If turned to yellow or red . Charge	Watch for sparks.		○
	External appearance	If soiled. Clean If deformed or cracked. Replace the battery	Watch for leak or being soiled with electrolyte.	○	
	Electrolyte port plug	Soiled, deformed or loosened. . . . Clean, Check, Retighten	Check for clogged plug hole.		
	Terminals and bracket	Loosened. Retighten Corroded. Clean	Watch for spark. Prevent leakage.	○	○
Maintenance	Replenishing with electrolyte	Replenish with distilled water upto specified level	Do not over-replenish.	○	
	Charging	ON Connect clips properly to ⊕ and ⊖ terminals, then close battery charger switch.	Perform the charging in the well ventilated place. Watch for current, temperature, generation of sparks, sulfuric acid mist or gas. Remove port plugs.	○	○
		OFF Open the battery charger switch then disconnect clips.			
	Tightening	Tighten terminals and mounting bracket firmly.	Avoid damaging by over-tightening or rattling. Avoid spark generation with tools, leak or damage.		○
Cleaning	Clean battery surface, terminals and bracket. Watch for clogging the filler port plug holes.		○	○	
Mounting & demounting of the battery	Terminal	Disconnect: Earthing end ⊖ first.	Watch for sparks.		○
		Connect: Earthing end last.			
	Mounting bracket	Demount: Disconnect at terminals first.	Tighten bolts and nuts to proper torque. Watch for sparks due to tools.	○	○
		Install: Do not allow looseness.			
Battery	Install: Select proper battery for the tractor (for replacement).	Watch for terminal positions of ⊕, ⊖.	○	○	
	Transport: Safely and surely.	Do not drop or bang.			
Storage	Battery with electrolyte	Select dry place without direct sun for storage.	Watch for leak or spark.	○	○
		Periodical make-up charge.			
Disposal of battery	Ask your local dealer for disposal.	Watch for short circuit or leakage of electrolyte. Particularly keep away from children.	○	○	

CHECKING THE ELECTROLYTE LEVEL

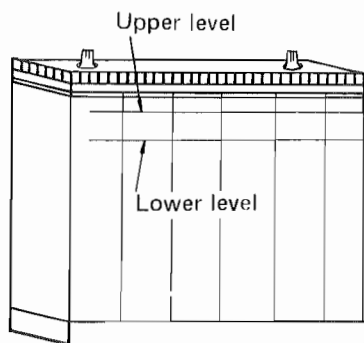

Battery electrolyte level

The amount of electrolyte should be between the lower and upper levels indicated on the outside of the battery case. Particularly in hot weather, frequently check the level of battery electrolyte.

WARNING

During battery inspection, watch for fire and be careful not to touch the electrolyte with clothing or part of your body. See "Basic Safety Requirements for Maintenance" in SAFETY PRECAUTIONS.

BATTERY RECHARGING

1. For charging the battery on this tractor, a slow charging operation should be carried out at 4.5 amp.
 2. In case the specific gravity is below 1.200, make lower rate charging at 3 amp.
- For more information, consult local dealer.

NOTE

Don't forget to turn off the lamp and don't treat the battery in such a way as may be discharged rapidly.

LUBRICATING THE TRACTOR METER CABLE

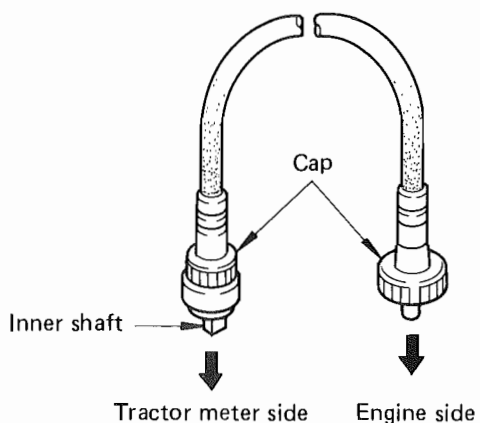

1. With the meter cable removed, pull out the wire from it.
2. Wipe the wire with cloth and dip it in engine oil for a minute or two.
3. Hang it for about five minutes to dry, then replace the cable. Install the cable being careful of the inner shaft direction.

TRANSMISSION OIL REPLACEMENT

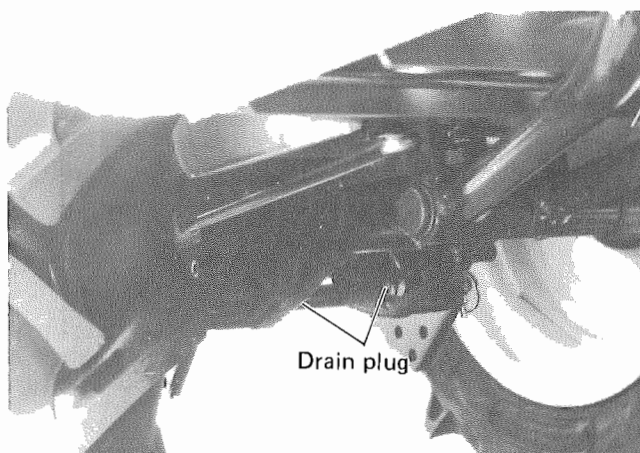

Remove the drain plugs, both right and left, under the rear part of the transmission case, and drain the transmission oil.

NOTE

When replacing the transmission oil, it is necessary to clean oil filter element at the same time.

To fill the transmission case with oil, tighten the drain plugs first, and remove the transmission oil level plug and then pour the oil into the filler port in the shift cover until oil overflows from the transmission oil level plug port.

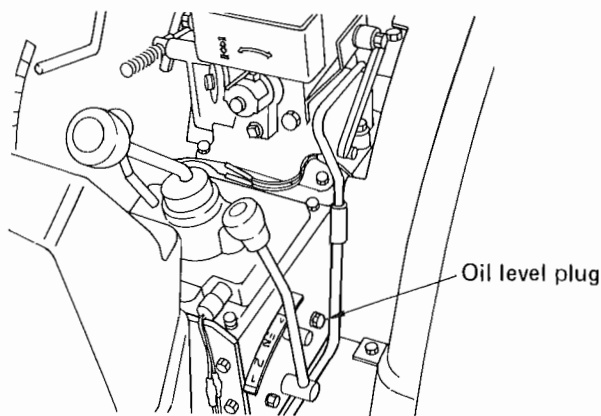

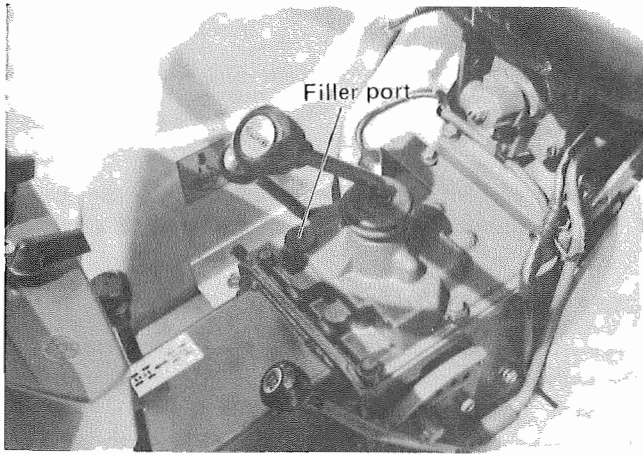

CLEANING THE HYDRAULIC OIL FILTER

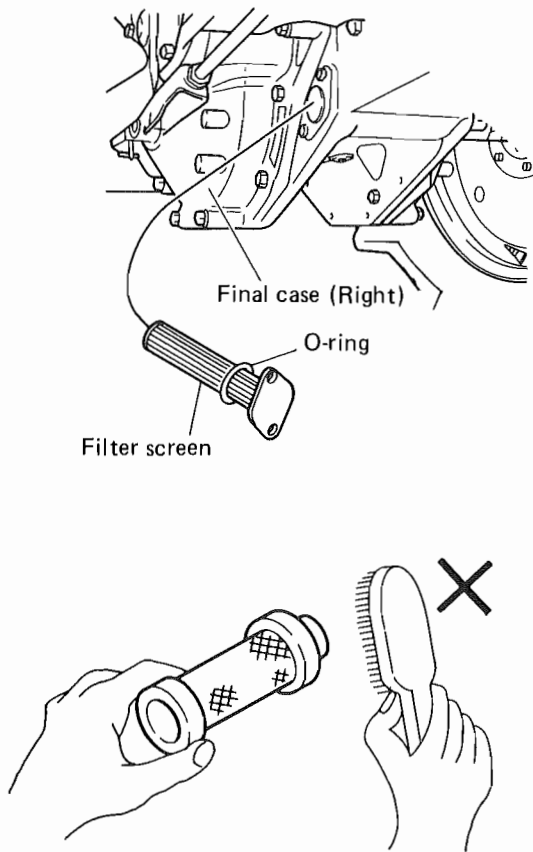

Remove the filter at the time of draining the transmission case oil, and clean the filter.

Loosen two bolts and remove the hydraulic oil filter under the right part of the transmission case.

The removed oil filter should be thoroughly cleaned in the detergent solution.

If the filter has been damaged, replace with a new one.

After installing the filter, make sure there is no oil leakage.

NOTE

1. If the transmission oil drained has to be reused, wipe clean the surrounding surfaces of the drain plug before draining, so that dust or dirt will not get into oil.
2. Oil replacement should be carried out in every 200 hours under normal operating conditions. If oil deteriorates excessively, replace it earlier than specified.
3. For installation of the oil filter make sure that the pipe end of the filter is securely inserted into the hole beside the suction pipe, and then install the cover.

CHECKING THE 4-WD FRONT AXLE OIL LEVEL AND ITS REPLACEMENT

CHECKING THE OIL LEVEL

Remove oil level plug to check that oil flows out. If not, add gear oil. For changing oil, refer to "LUBRICATION TABLE".

Specified quantity: MT180HD – 2.5 ℓ (3/5 gal, 1/3 quart)

REPLACING THE OIL OF FRONT AXLE

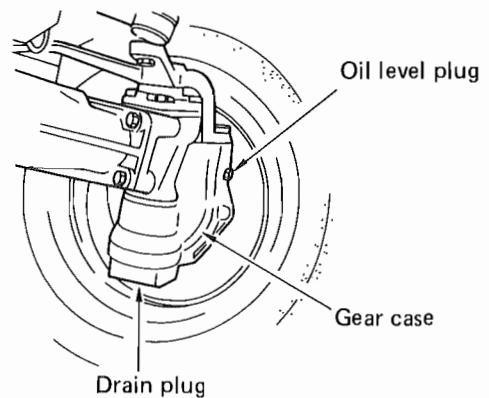
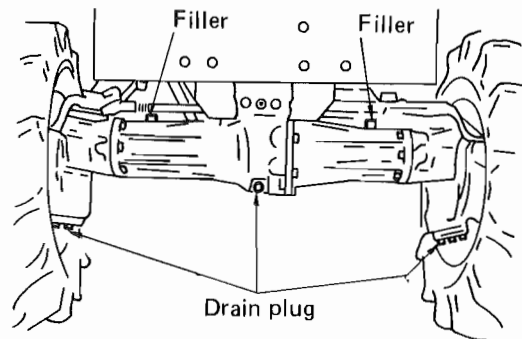

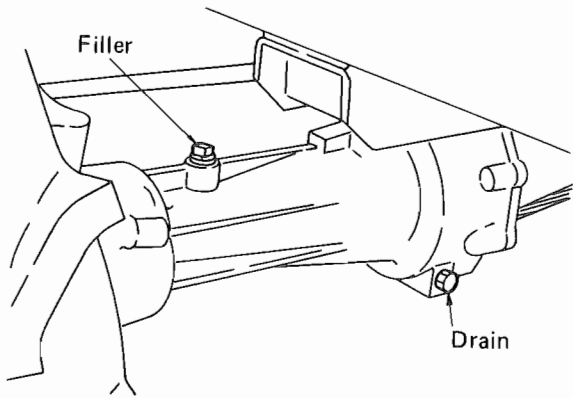

1. Remove drain plugs (3 locations) and let the oil flow out.
2. Wrap the drain plugs with sealing tape and tighten it.
3. Enter new gear oil specified through filler port.

CAUTION

Replace oil at the first 50m hours and in every 200 hours thereafter.

CLEANING THE RADIATOR SCREEN

1. Open the bonnet and remove the radiator screen.
2. After removing large dust, straw, etc. with hand, rinse with clean water.

CLEANING THE RADIATOR

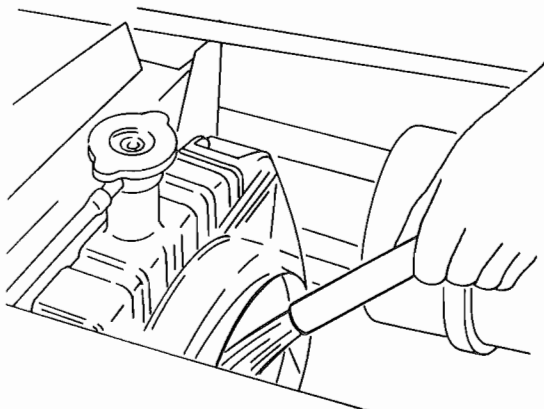
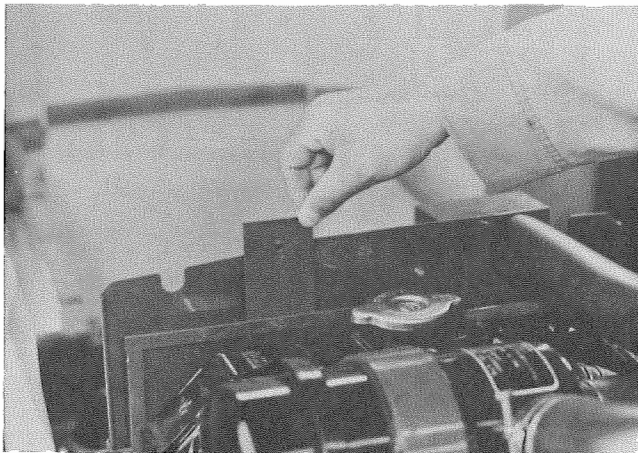

1. Check the radiator for clogging, and remove large dust, straw, etc. if any, first with hand.
2. Blow with clean water to wash away remaining dust or straw.

CAUTION

Be careful not to damage the radiator since damaged or deformed radiator will reduce the cooling efficiency.

CLEANING THE INSIDE OF RADIATOR

Clean radiator and engine coolant system with cleanser in the following cases:

- After 600 hours of operation
- Adding anti-freeze.
- Replacing coolant eliminating anti-freeze.

CAUTION

For cleaning the radiator, read the instruction on cleanser carefully, and observe the instruction.

CLUTCH PEDAL ADJUSTMENT

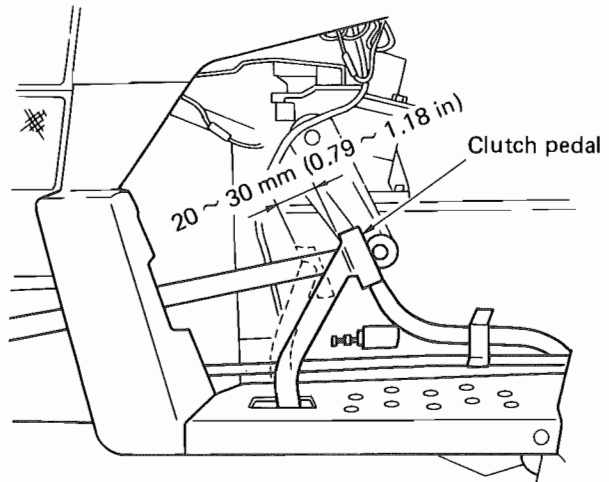

Clutch pedal free play is very important and it must be always maintained to be correct. If there is no free play, the clutch disc will wear quickly, while too much free play will cause difficult disengagement of the clutch even if the pedal is fully depressed, resulting in hard gear shift.

- Amount of free play should be 20 to 30 mm (0.79 to 1.18 in.)
- Adjust it in the following manner:
 - 1) Remove the snap pin and clevis pin of clutch rod.
 - 2) Adjust the amount of play by turning the joint.
 Turn-in Reduces the amount of play
 Turn-out Increases the amount of play

NOTE

This adjustment is important for maintaining the clearance between the release lever and the release bearing to obtain a smooth gear shift and transfer all the driving power to the transmission.

BRAKE PEDAL ADJUSTMENT

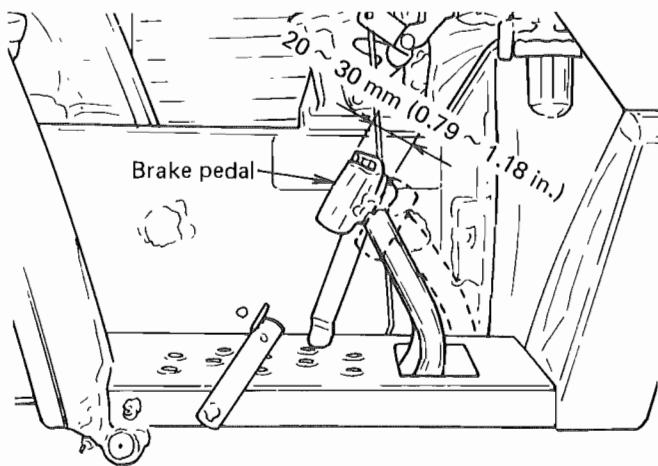

Free play of the brake pedal must be maintained within the correct range, otherwise, accident may occur or power will be lost.

Before the brake on one side becomes unadjustable even by means of the rod, caused by earlier wear of the brake lining due to its more frequent use than the other, periodically interchange the right and left brake shoes. Special care should be taken in the case of more frequent using one brake than the other.

The play of the brake pedal is appropriate if it is 20 to 30 mm (0.79 to 1.18 in.).

Adjust it in the following manner.

1. Remove a joint pin at the rear of brake rod, and loosen locknut.
2. Adjust the amount of play by turning the joint.
Turn-in Reduces the amount of play
Turn-out Increases the amount of play

After obtaining the specified dimensions on each side, check the performance in the following procedure:

- Effectiveness
Perform the single-side braking and pivot turn to make sure of the effectiveness of the brakes (each side).
- Uneven braking
Interlock the right and left brake pedals with link plate and drive the tractor normally. Step on both brake pedals simultaneously and check the trace of tire slippage for uneven braking. If the tractor stops straight, braking is normal. If it stops with turning, readjustment is required.

DIFFERENTIAL LOCK PEDAL ADJUSTMENT

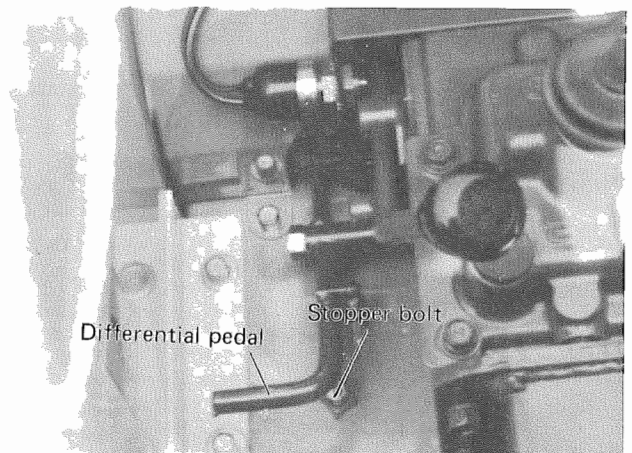

Loosen the lock nut on the differential lock pedal stopper, and screw in the stopper bolt. With pedal depressed, adjust the stopper bolt so that it lightly contacts the pedal. Then, screw out the stopper bolt by a quarter to half turn and lock the stopper bolt.

THROTTLE LEVER ADJUSTMENT

The engine speed can be controlled by operating the throttle lever on the right side of the instrument panel. The range of speed control is as follows:

Low idle speed 900 rpm
High idle speed 2,900 rpm

1. Place the throttle lever in the low idle speed position, and loosen the nut securing the speed control rod to the joint. While watching the tractor meter on the instrument panel, turn the nut so that the engine idles at 900 rpm, and lock the nut.
2. Pushing the throttle lever fully forward makes the engine to run at the maximum of 2,900 rpm.
3. Pulling the throttle lever fully rearward causes the engine to run at the low idle speed.

NOTE

1. The high speed adjusting bolt is pre-adjusted and sealed, before leaving the factory, so that the engine runs at the specified maximum speed with the throttle lever pushed fully forward. If such specified speed is not obtained, consult Mitsubishi dealer.
2. Adjust the throttle lever properly with the nut at the throttle lever supporting point so that it may not be moved by the vibration of the engine nor by the tensed governor spring and besides, may control the engine speed smoothly enough.

HYDRAULIC CONTROL ADJUSTMENT

The hydraulic control link has been carefully adjusted in the factory, so that adjustment is hardly ever necessary. However, if it is not working correctly, adjust it in the following manner:

When carrying out this adjustment, stop and start the engine as required.

POSITION CONTROL ADJUSTMENT

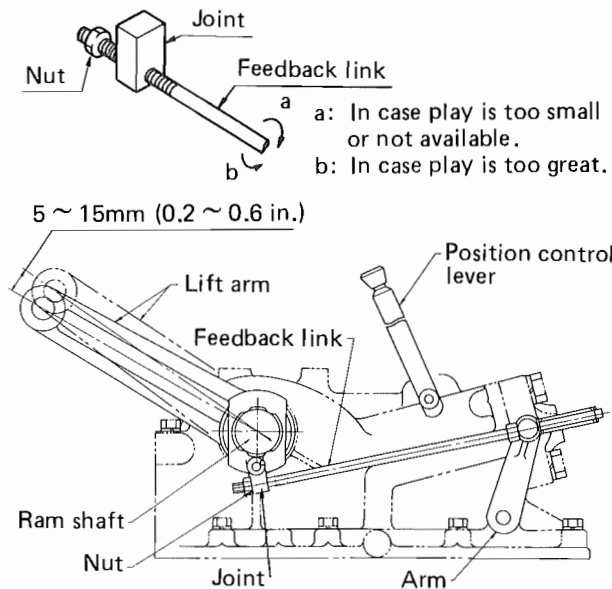

Start the engine, and operate the hydraulic control lever to raise the lift arm to the maximum lifting position without implement. With the arm so raised, stop the engine, and check to be sure that there is a play of 5 to 15 mm (0.2 ~ 0.6 in.) at the top of the lift arm by hand.

- Move stop lever on lifting end all the way and fix it there.
- Have a lift rod for implement removed off the lift arm.
- With engine running at about 1,000 rpm, raise the control lever until it contacts the stopper and check the amount of play at lift arm end to be about 5 ~ 15 mm (0.2 ~ 0.6 in) with the lift arm lifted.

NOTE

Without this play, hydraulic circuit will be subjected to unnecessary pressure when implement is lifted, causing trouble.

- If play is too small or not available, loosen feed back link nut and turn the feed back link to the direction of lift arm for adjustment (tightening direction).
- If play is too great, adjust it in direction away from lift arm (loosening direction).
- Be sure to lock the feed back link nut after adjustment without fail.

- After adjustment, attach implement and raise engine speed slightly (over 1,500 rpm). Operate hydraulic control lever to lift and lower the implement several times to check the function.



CAUTION

Be sure to check that there is no relief sound (beeps) generated after adjustment.

HYDRAULIC PUMP RELIEF VALVE

The hydraulic system is equipped with a pump relief valve to protect the hydraulic pump and pipe line against accidents caused by high hydraulic pressure in the system. The set pressure is 135 kg/cm² (1,920 psi) at full flow. Never disturb nor disassemble the pump relief valve since its adjustment requires special tools and instruments.

AC GENERATOR

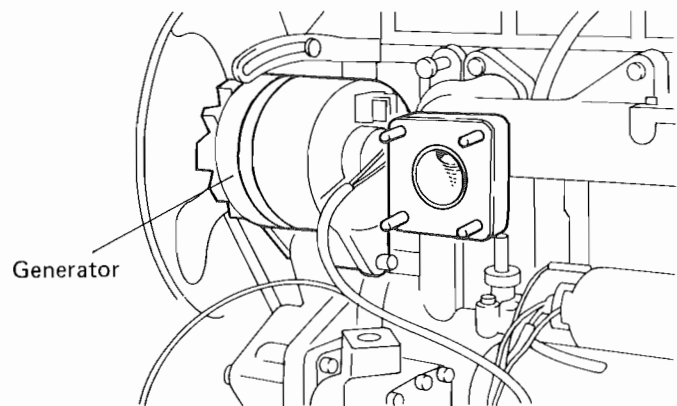

The generator is of an alternator type. Seal bearings are employed for this generator, so that lubrication is not necessary.

During maintenance, pay attention to the following points.

1. The generator is negative-grounded and if the polarity is reversed, the diode will be damaged. Be careful enough when connecting it to the battery.
2. As the battery voltage is always connected to the terminal A, never run the engine with the terminal A disconnected.
3. Don't water the alternator at high pressure.
4. Pay full attention to the belt tension so that normal charging may be made.
5. During operation, be sure to set the starter switch at "ON".
6. If difficulties are experienced, consult Mitsubishi dealer.

STARTING MOTOR

Facilities and instruments are necessary for servicing the starter motor. When the rotational force of the motor is weak, measure the battery voltage because it may be caused by insufficient battery capacity. When the voltage is correct and there is still inferior rotation, let your dealer check the carbon brush for deterioration and magnetic switch for defective performance. The motor sometimes does not start even when the light is sufficiently bright. The cause may be due to trouble in the regulator or a loose battery terminal connection.

When the starter motor does not operate, don't continue to drive it because it will result in damage to the motor or battery. In this case, consult your dealer.

REGULATOR

The regulator is an important part for the electrical system protection of your tractor. When trouble occurs with the regulator, consult your dealer because specific knowledge and special instruments are required to repair it.

GLOW PLUG

The glow plugs are of a sheathed type and connected in parallel. Therefore, if one of the plugs is disconnected, performance is not totally defective. When the heat wire of the glow plug is disconnected, the preheat time of the control resistance is abnormally prolonged. When the center polarity, the body and the sheath come in contact with one another, the glow signal lamp will be heated quickly and the wiring of the pre-heated circuit will burn out.

FUSE

A fuse is installed in the circuit to protect the electrical system against trouble.

The fuse capacity is 10 A, and it is placed in the fuse box under the instrument panel. If the fuse is burned out, check for the possible cause first, and replace it with a specified one. Never use a fuse of a large capacity.

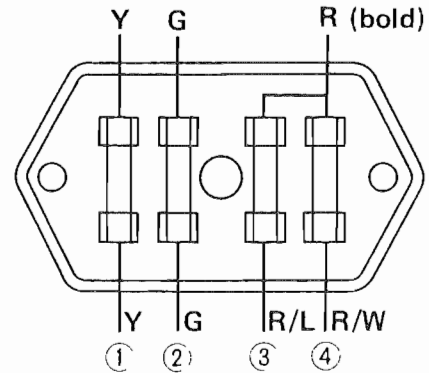

- 1 Combination flash and turn signal lights
- 2 Horn and work light
- 3 Instrument lights
- 4 Headlights and red tail light

Fuse box

SECTION 7. STORING

STORAGE

A tractor should be stored in a dry and protected place when it is left without use for some period. It should be noted that leaving a tractor outdoors will result in shortened life of the tractor.

For storing the tractor please follow the procedures shown below:

1. After washing and cleaning the tractor be sure to lubricate it. And if hydraulic implement is mounted apply rustinhibiting grease to all the exposed cylinder or piston rod surfaces.
2. Run the engine until oil in the crankcase gets warm enough, then drain oil and replace oil filter. Refill the crankcase with fresh oil specified in the "LUBRICATION TABLE " and run the engine for five minutes or so.
3. Store the tractor in the place where the tires may not be in the sun. Before storing wash and clean the tires. In case of long term storage jack up the tractor so that the tires may be under no load. When the tractor is not jacked up inflate the tires periodically.
4. After the engine gets cooled enough, pour one table-spoonful of engine oil from the air breather pipe. To distribute the oil all over the cylinder walls, crank the engine for five or ten seconds. Be sure to reinstall the breather hose on the pipe after pouring oil.
5. Drain the engine cooling system and fill it with a mixture of antifreeze and water as specified on the container for the lowest expected temperature.
6. Fill the fuel tank with fuel, and clean the fuel filter.
7. Plug up the end of the exhaust pipe.
8. Clean the air cleaner and then cover it so as to seal the air intake system.
9. Check the battery for proper electrolyte level and specific gravity at least once a month. In order to increase the durability as well as prevent freezing, the battery should be kept fully charged all the time.
10. Hold the clutch at the disengaged position in use of clutch lock, so that clutch facing will be prevented from sticking to the flywheel or clutch pressure plate.

REOPERATION AFTER STORAGE

1. Check to make sure that viscosity of the oil in the engine crankcase is as specified in "LUBRICATION TABLE".
2. Remove the plug from the exhaust pipe.
3. Remove the cover over the air cleaner.
4. Check to make sure that the battery is fully charged and the terminal is clamped tightly enough.
5. Fill the fuel tank.
6. Release the clutch pedal.
7. Just like the case of storing, pour a table spoonful of engine oil from the breather pipe and crank the engine while pushing the rubber part of solenoid switch for five or ten seconds to prevent engine from starting.

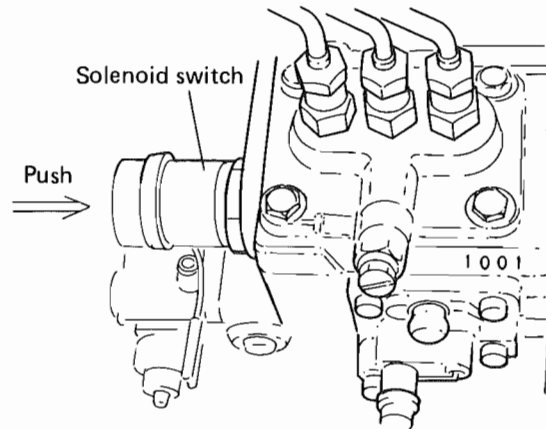

8. Start the engine as described in "STARTING AND STOPPING THE ENGINE" and let it run slowly. Do not accelerate the engine rapidly or operate it at high speed immediately after starting.

SECTION 8. WIRING DIAGRAM

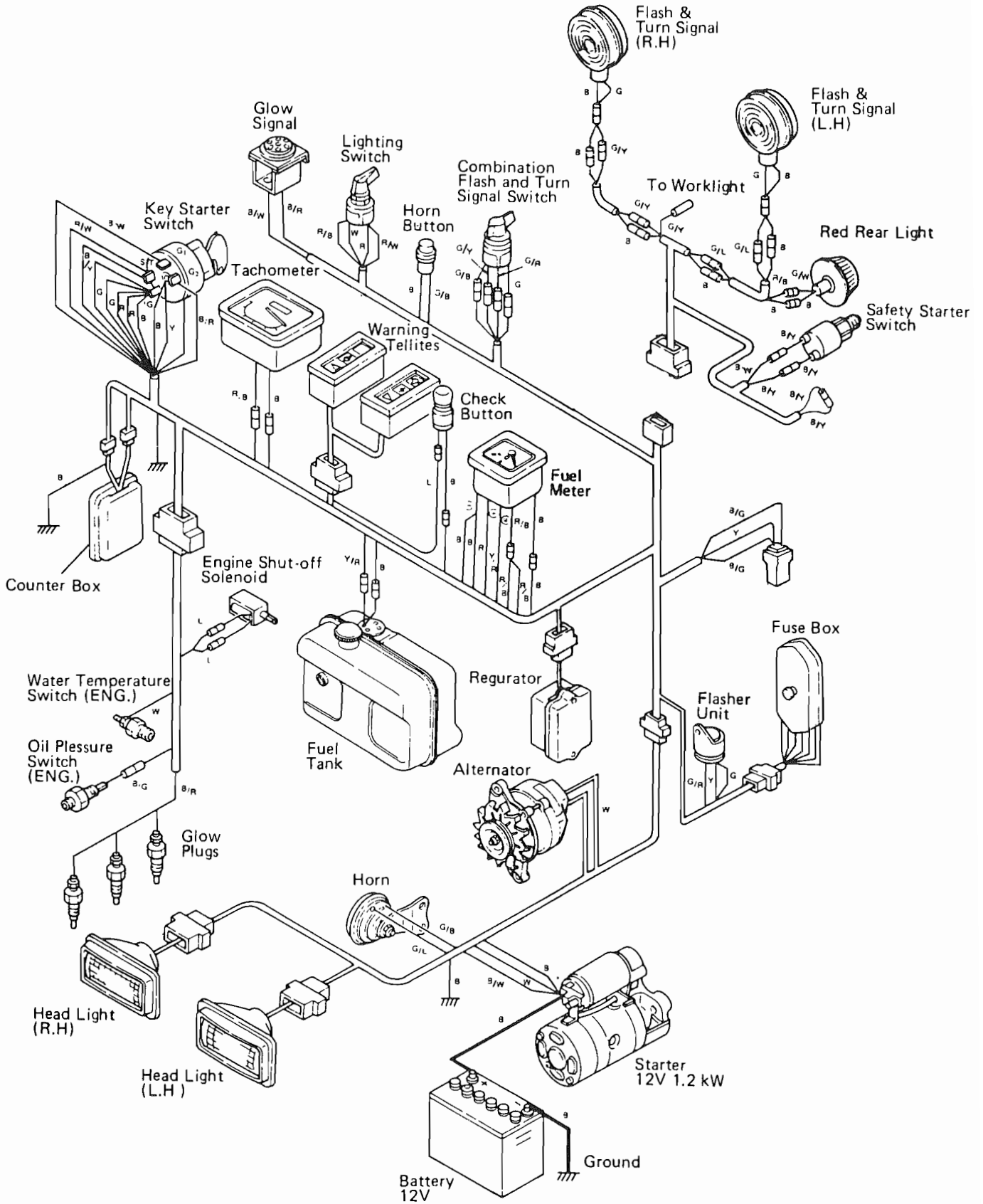

SECTION 9. SPECIFICATIONS AND DATA

ENGINE (Mitsubishi Diesel Engine)

MT160

MT180

Model	K3A	K3C
Type	Water cooled vertical 4-cycle overhead valve in line diesel engine	
Number of cylinder	3	
Piston displacement	776 cc (47.35 cu.in.)	900 cc (54.91 cu.in.)
Bore x Stroke	65 x 78 mm (2.56 x 3.07 in.)	70 x 78 mm (2.76 x 3.07 in.)
Compression ratio	23 : 1	
Max. bare horse power	16.5 Hp/2,700 engine rpm	18.5 Hp/2,700 engine rpm
Max. torque	4.6 kg-m/1,900 engine rpm	5.3 kg-m/1,600 engine rpm
Max. engine rpm	2,900 \pm 75 rpm	
Idling speed	925 \pm 25 rpm	
Compression pressure	32 kg/cm ² (455 psi) at 280 engine rpm	
Injection order	1 - 3 - 2	
Weight	125 kg (276 lb) at dry	
Valve clearance Intake	0.25 mm (0.01 in.) at cold	
Exhaust	0.25 mm (0.01 in.) at cold	

COOLING SYSTEM

Radiator cap pressure	0.9 kg/cm ² (12.8 psi)
Water pump	Centrifugal impeller type

FUEL SYSTEM

Fuel	No. 2 Diesel fuel
Fuel injection pump	Bosch M type
Injection nozzle	Throttle type
Fuel filter	Paper element type

LUBRICATION SYSTEM

Oil pump	Trochoid type pump
Oil filter	Paper element filter cartridge type
Oil pressure	4 kg/cm ² (56.9 psi) at cold

AIR CLEANER

Type	Cyclone dry air cleaner
Filter	Dry paper element type

GOVERNOR

Type	Mechanical centrifugal type
------------	-----------------------------

ELECTRICAL SYSTEM

Battery (Outside North America)	Model NX100S6L (S) (12V - 45Ah)
Generator	12V - 35A
Starting motor	12V - 1.6kW Magnet type
Glow plug	10.5V - 30A
	(Speed heating sheathed type)

CHASSIS

DIMENSIONS

	MT160		MT180	
	2-WD	4-WD	2-WD	4-WD
Model	2-wheel drive	4-wheel drive	2-wheel drive	4-wheel drive
Overall length (To end of tire)	2,200 mm (86.6 in.)	2,200 mm (86.6 in.)	2,225 mm (87.6 in.)	2,225 mm (87.6 in.)
Overall width	975 mm (38.4 in.)	975 mm (38.4 in.)	940 mm (37.0 in.)	970 mm (38.2 in.)
Overall height (To steering wheel)	1,155 mm (45.5 in.)	1,165 mm (45.9 in.)	1,175 mm (46.3 in.)	1,185 mm (46.7 in.)
Wheelbase	1,422 mm (56.0 in.)	1,422 mm (56.0 in.)	1,422 mm (56.0 in.)	1,422 mm (56.0 in.)
Ground clearance	260 mm (10.2 in.)	215 mm (8.46 in.)	280 mm (11.0 in.)	215 mm (8.46 in.)
Tread (w/AG tire)				
Front	720 mm (28.3 in.)	785 mm (30.9 in.)	720 mm (28.3 in.)	785 mm (30.9 in.)
Rear	740 and 890 mm (29.1 and 35.0 in.)		740 and 890 mm (29.1 and 35.0 in.)	
Weight.	565 kg (1,246 lb)	615 kg (1,356 lb)	575 kg (1,268 lb)	625 kg (1,378 lb)
Turning radius (with brakes)	1,850 mm (72.8 in.)	1,850 mm (72.8 in.)	1,850 mm (72.8 in.)	1,850 mm (72.8 in.)

CLUTCH

Clutch type Dry single plate

TRANSMISSION

Number of shift lever 2
No. of speeds 6-Forward 2-Reverse
Speed shift type Sliding gear type
Differential gear Bevel gear type
Differential lock With differential lock

POWER TAKE OFF

Power take off shaft. 1-3/8" 6 spline SAE standard
PTO Shaft speed 623, 919, 1,506 rpm/2,700 engine rpm
Standard PTO speed. (1st) 540 rpm/2,340 engine rpm
(3rd) 1,000 rpm/1,793 engine rpm
Direction of rotation Clockwise as viewed from the rear

BRAKE

Type Foot operating internal expansion water-proof dry type
Parking brake Locking main brake by hand operating lever

STEERING

Steering type Ball screw type
Toe-in (2-WD) 5 ~ 8 mm (0.20 ~ 0.31 in.)
(4-WD) 0 ~ 6 mm (0 ~ 0.24 in.)

HYDRAULIC SYSTEM (Mitsubishi live hydraulic system)

Control

Type of cylinder

Pressure of relief valve

Pump model

Output of hydraulic pump

Type of hydraulic pump

Implement lock valve

Hydraulic oil

External service

Hydraulic adapter plate

MT160

Position (lifting and lowering), down speed control and lock.

Single acting cylinder

135 kg/cm² (1,920 psi)

GP-3607A

12.9 ℓ (3.4 gal)/min at 2,700 engine rpm (Design output)
[5.25 cc/rev. (0.32 cu.in./rev.)]

Pressure loading type
With lock valve

Refer to "LUBRICATION TABLE"

PT3/8 Tap

Optional

MT180

3-POINT LINKAGE

Top hitch pin hole dia.

Lower link stud hole dia.

Width of cross-shaft

Category 1.

19.5 mm (0.77 in.)

22.5 mm (0.89 in.)

683 mm (26.9 in.)

DRAWBAR

Type

Max. drawbar pull (2-WD)

(4-WD)

Fixed type

390 kg (860 lb)

590 kg (1,301 lb)

TIRE

MT160/D		Tire size	Ply	Lug pattern	Allowable load/Air pressure
AG	Front (2-WD)	4.00-9	4	Farm service rib	200 kg/3.25 kg/cm ² (441 lb/46.2 psi) (One side)
	Front (4-WD)	5-12	4	Farm service lug	210 kg/2.2 kg/cm ² (463 lb/31 psi) (One side)
	Rear (2 & 4-WD)	8-16	4	Farm service lug	475 kg/1.6 kg/cm ² (1,047 lb/23 psi) (One side)
ES	Front (2-WD)	18x7.00-8	4	Pillow dia.	300 kg/2.0 kg/cm ² (661 lb/28 psi) (One side)
	Front (4-WD)	6-12	4	All weather	270 kg/2.0 kg/cm ² (595 lb/28 psi) (One side)
	Rear (2 & 4-WD)	9.5-16	4	All weather	555 kg/1.4 kg/cm ² (1,223 lb/20 psi) (One side)

MT180/D		Tire size	Ply	Lug pattern	Allowable load/Air pressure
AG	Front (2-WD)	4.50-10	4	Farm service rib	235 kg/2.8 kg/cm ² (518 lb/40 psi) (One side)
	Front (4-WD)	5-12	4	Farm service lug	210 kg/2.2 kg/cm ² (463 lb/31 psi) (One side)
	Rear (2 & 4-WD)	8-18	4	Farm service lug	520 kg/1.6 kg/cm ² (1,146 lb/23 psi) (One side)
ES	Front (2-WD)	20x8.00-10	4	Pillow dia.	400 kg/1.6 kg/cm ² (882 lb/23 psi) (One side)
	Front (4-WD)	6-12	4	All weather	270 kg/2.0 kg/cm ² (595 lb/28 psi) (One side)
	Rear (2 & 4-WD)	9.5-18	4	All weather	600 kg/1.4 kg/cm ² (1,323 lb/20 psi) (One side)

TRAVELLING SPEED

MT160/D Tire size 8–16

MT180/D Tire size 8–18

AG 2-WD and 4-WD at engine speed 2,700 rpm

	Km/Hr	m/Sec.	Mile/Hr	Km/Hr	m/Sec.	Mile/Hr
F-1	1.2	0.33	0.75	1.2	0.33	0.75
F-2	1.8	0.50	1.12	1.9	0.53	1.18
F-3	3.0	0.83	1.86	3.2	0.89	1.99
F-4	5.1	1.42	3.17	5.4	1.50	3.35
F-5	7.7	2.14	4.78	8.2	2.28	5.09
Max. F-6	13.2	3.67	8.20	14.5	4.03	9.00
R-1	1.5	0.42	0.93	1.6	0.44	0.99
R-2	6.5	1.81	4.04	6.9	1.92	4.28

CAPACITIES

Engine oil	3.0 ℓ (3/4 gal. 1/3 pt.)
Fuel tank	18.0 ℓ (4 gal. 3 qt.)
Cooling water	5.0 ℓ (1 gal. 1-1/4 qt.)
Transmission oil	12.0 ℓ (3 gal. 2/3 qt.)
Hydraulic oil	Same as transmission oil
Steering gear box.	200 cc (3/7 pt.)
4-WD front axle (with diff. case)	2.5 ℓ (1/2 gal. 2/3 qt.)

* Specifications are subject to change without notice.

MEMO

 MITSUBISHI AGRICULTURAL MACHINERY CO., LTD.

6-3, KANDA KAJICHO 3-CHOME, CHIYODA-KU,
TOKYO JAPAN

Publication No. 1986 2971 000
Printed in Japan (K)